

Universal Controller

Operating Instructions/
Descriptions

controller 2000/2020/5350



| Contents | Page |
|--|-------------|
| Order Code..... | 3 |
| Connection diagram | 3 |
| Installation instructions | 5 |
| Technical data | 6 |
| Display and keyboard..... | 8 |
| Adjustment of parameter values | 9 |
| Function levels..... | 10 |
| Configuration level..... | 11 |
| Parameter level | 18 |
| Operating level | 22 |
| Hints for using the serial interface | 24 |
| Process value output (as casting device) | 25 |
| Error messages | 26 |
| Accessories (to be ordered seperately)..... | 26 |
| Parameterlist | 27 |

Please read this operating manual carefully before starting up.

Observe the installation and connecting instructions

Order Code

2000 (48x96 mm)
2020 (96x48 mm)

- 1 Power supply: AC 230 V (internal jumper: AC 115 V)
- 2 Power supply DC 24 V

Output

- A switching controller Relay (max. AC 250V, 3A) and voltage, bistable (0/18VDC)
- B switching and steady working controller Relay (max AC 250V, 3A) and voltage, bistable (0/18VDC) and current (steady 0/4...20mA) and voltage (steady 0...10VDC)
- 0 without interface
- 1 with interface serial RS485

Accessories

FK Front-adapter 96x96mm (plastics)
FA Front-adapter 96x96mm (aluminium)

Connection diagram 2000-1-...-0

Control output, continuous (Option)

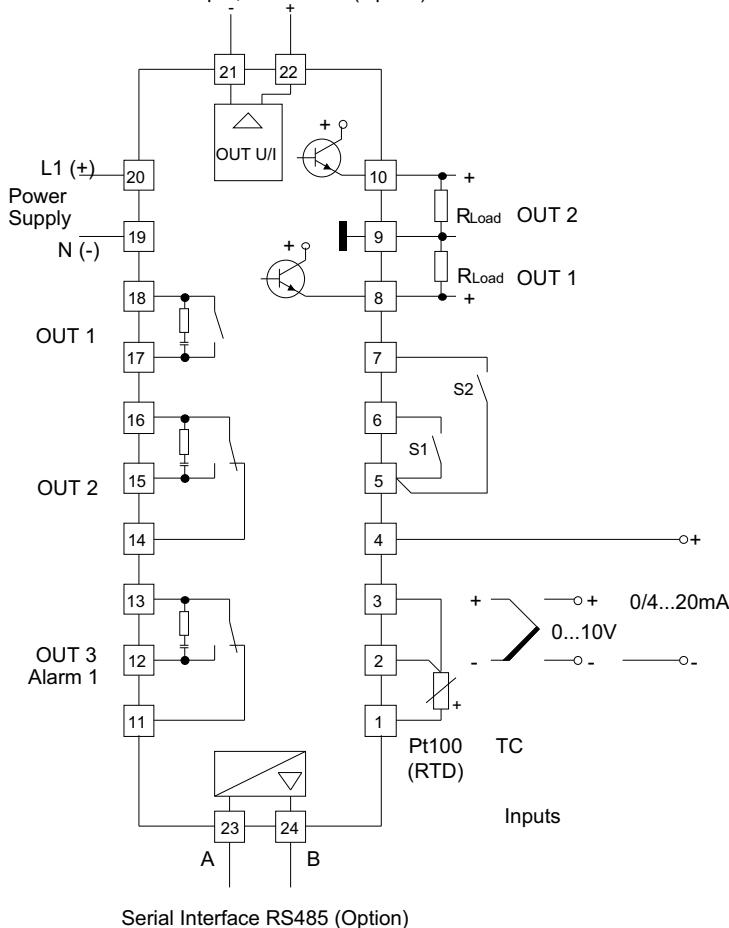

Control output OUT 1

2-point/continuous: "heating" or "cooling"
Heat-cool-controller: "heating"
Three-point-step-controller: "open"

Control- or alarm output OUT 2

2-point /: alarm 2
Heat-cool-controller: "cooling"
Three-point-step-controller: "close"

Setpoint setting

S1: open = SP1 valid
S1: closed = SP2 valid

Adjustment lock (LOC)

S2: open = Adjustment lock only via "software code"
S2: closed = Adjustment locked (according to the chosen software code)

Important: It is not permitted to connect the grounds of the sensor-, bistable voltage- and continuous – outputs with each other!

Connection diagram 5350

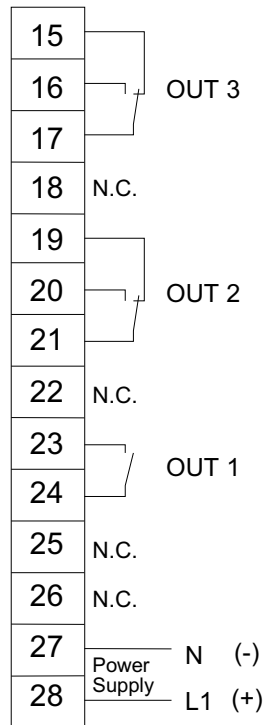
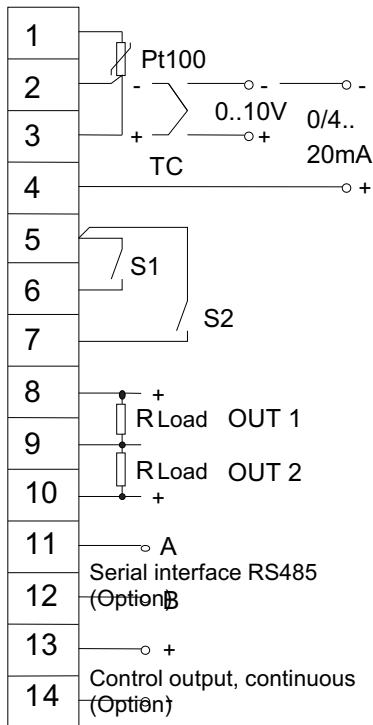

Control output OUT 1

2-point / continuous controller: "heating or "cooling"

Three-point-step-controller: "heating"

Three-point-step-controller: "open"

Control- or alarm output OUT 2

2-point-/continuous controller: Alarm 2

Heat cool controller: "cooling"

Three-point-step-controller: "close"

Setpoint setting

S1: open = SP1 valid

S1: closed = SP2 valid

Adjustment lock (LOC)

S2: open = Adjustment lock only via "softwarecode"

S2: closed = Adjustment locked

(according to the chosen softwarecode)

It is not permitted to connect the grounds of the sensor-, bistable voltages- and continuous – outputs with each other!

Installation instructions

Make certain that the devices described here are used only for the intended purpose. They are intended for installation in control panels.

The controller must be installed so that it is protected against impermissible humidity and severe contamination.

In addition, make sure that the permitted ambient temperature is not exceeded.

The electrical connections must be made according to the relevant German VDE directives and locally applicable regulations.

Transducer cables and signal lines (e. g. logic output lines) must be laid physically separated from control lines and main voltage supply cables (power cables).

If using a thermocouple sensor, the compensation cables should be laid directly to the controller terminals.

Transducers must be connected only in compliance with the programmed range.

Physical separation between controller and inductive loads is recommended.

Interference from contactor coils must be suppressed by connecting adapted RC-combinations parallel to the coils.

Control circuits (e. g. for contactors) should not be connected to the power supply terminals of the controller.

Important

Before operation, the unit must be configured for its intended purpose (e.g. controller type, sensor-type, alarm adjustment etc.).

Please see configuration level.

Device installation

The instrument (2000-1-A-0 / 200-1-B-0) is constructed with plug-in technology. The instrument can be drawn out of the housing together with the front panel. This, however, can only be done after the instrument has been isolated from its power supply.

Technical data

Inputs:

- TC:

Built-in internal compensation point and protection against sensor breakage and incorrect polarity.

Re-calibration not required for a line resistance of up to 50 Ohm.

Calibration accuracy: 0,25 %

- Pt 100 (RTD):

2- or 3-wire connection possible.

Built-in protection against sensor breakage and short-circuit.

Maximum permissible line resistance by 3-wire connection: 80 Ohm

Sensor current: 0,5 mA

Calibration accuracy: 0,2 %

- Standard signals:

DC 0 to 20 mA, 4 to 20 mA ($R_i < 10 \text{ Ohm}$)

DC 0 to 10 V, ($R_i > 100 \text{ k-Ohm}$)

Calibration accuracy: 0,2 %

Linear error: 0,2 %

Influence of the ambient temperature: 0,01 % / K

- Setpoint switch-over:

external potential-free contact (switches voltage of app. DC 24 V, max. 1 mA)

Control outputs:

- **OUT 1:** Relay, (n/o contact) max. AC 250 V, 3 A at $\cos\phi = 1$ and bistable voltage, DC 0/18 V, max. 10 mA, short-circuit proof

- **OUT 2:** Relay, (changeover contact) max. AC 250 V, 3 A at $\cos\phi = 1$ and bistable voltage, DC 0/18 V, max. 10 mA, short-circuit proof

- **OUT 1:** Stetig (nur bei Version - 611)

Continuous (additionally for version -611-) Output type (current or voltage) is determined automatically, dependent on load.

DC 0/4...20 mA, load of < 500 Ohm

DC 0/2...10 V, load of > 1 k-Ohm

Linearity: < 1,5 %

Calibration accuracy < 1,0 %

Delay: app. 2 s

Alarm outputs:

- **OUT 2:** Relay, (changeover contact) max. AC 250 V, 3 A at $\cos\phi = 1$ Only for 2-point-controller (heat-only or cool-only) configuration and continuous-controller configuration.

- **OUT 3:** Relay, (changeover contact) max. AC 250 V, 3 A at $\cos\phi = 1$

7-Segment-display:

10 mm red (Process)

7,6 mm red (Set)

Data protection:

EAROM, semiconductor memory

Serial interface:

RS 485 (Option)

EMC:

CE-marked according to EN 50081-2 and EN 50082-2

Power supply:

- **AC 230 V**, (internal jumper: AC 115 V , jumper from "a-b" (230 V) to "b-c" (115 V))
 $\pm 10 \%$, 48 to 62 Hz
 Typ 2000-1-A-0/2000-1-B-0 : Pull out the device out of the housing together with the front panel
 Type 5350: Remove rear cover, then pull out half the PCB's by holding the orange plug of the CPU-Board.
 The jumper on the powersupply-PCB is now accessible.

Attention! This device has to be connected to fused power supply only.

- **AC 24 V**, $\pm 10 \%$, 48...62Hz
- **DC 24 V**, $\pm 20 \%$, permissible residual ripple max. 5 % r.m.s.

app. 4,5 VA power consumption

Connections:

Screw terminals, Protection mode IP 20 (DIN 40050), Insulation class C
 (connector / terminal board – 5350)

Permissible operating conditions:

Operating temperature: 0...50 °C / 32...122 °F
 Storage temperature: -30...70 °C / -22...158 °F
 Climate class: KWF DIN 40040;
 equivalent to annual average max. 75 % relative humidity. No condensation.

Housing:

| | |
|----------------|--|
| Format: | 48 mm x 96 mm (DIN 43700), Installation depth 112 mm |
| (2000-1-A-0) | |
| | 96 mm x 48 mm (DIN 43700), Installation depth 112 mm |
| (2000-1-B-0) | |
| | 96 mm x 96 mm (DIN 43700), Installation depth 122 mm |
| (5350) | |
| Panel cutout : | 45 mm + 0,6 mm x 92 mm + 0,8 mm (2000-1-A-0) |
| | 92 mm + 0,8 mm x 45 mm + 0,6 mm (2000-1-B-0) |
| | 92 mm + 0,8 mm x 92 mm + 0,5 mm (5350) |
| Unit: | replaceable from front (2000-1-A-0, 2000-1-B-0) |
| Material: | Noryl, self-extinguishing, non-drip, UL 94-V1 |
| Enclosure: | IP 20 (DIN 40050), IP 54 front side |

Weight:

ca. 450 g (2000-1-A-0)
 ca. 450 g (2000-1-B-0)
 ca. 600 g (5350)

Display and keyboard

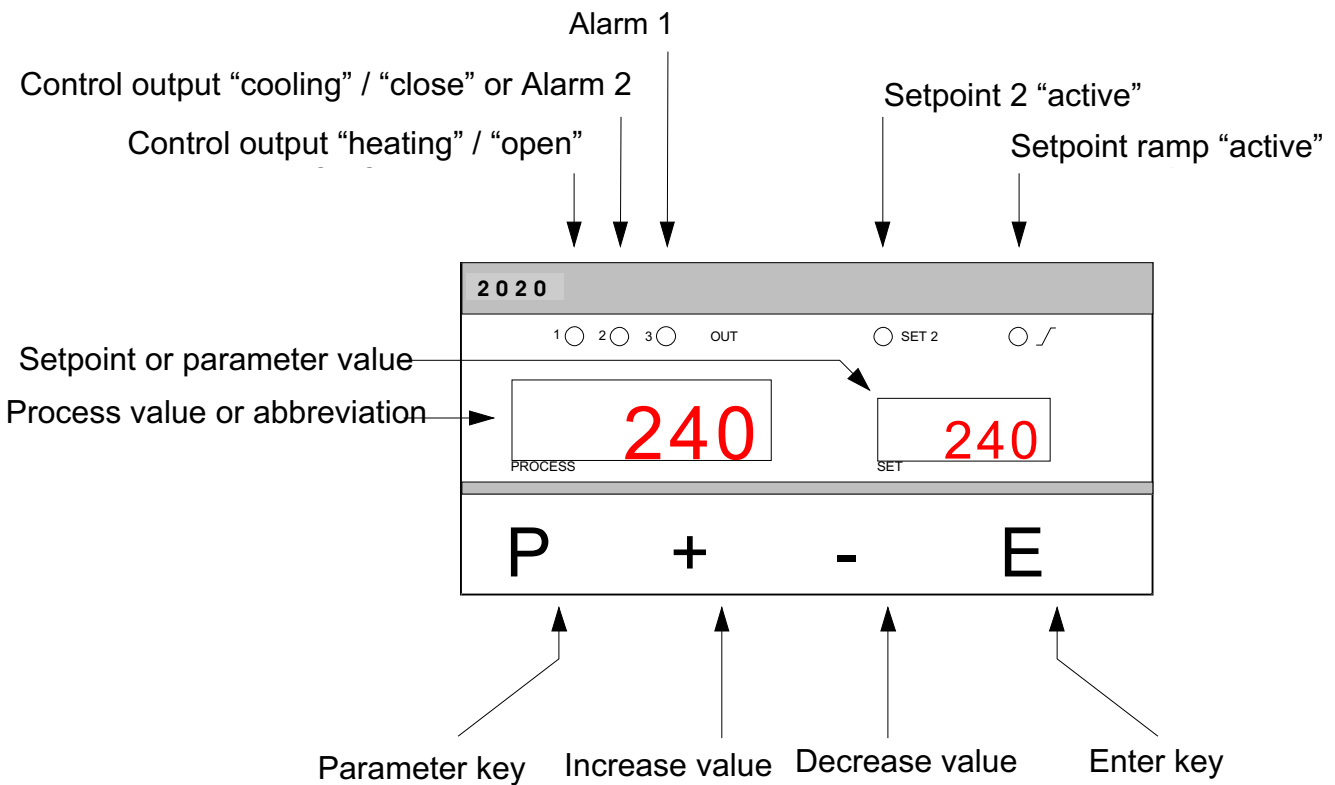
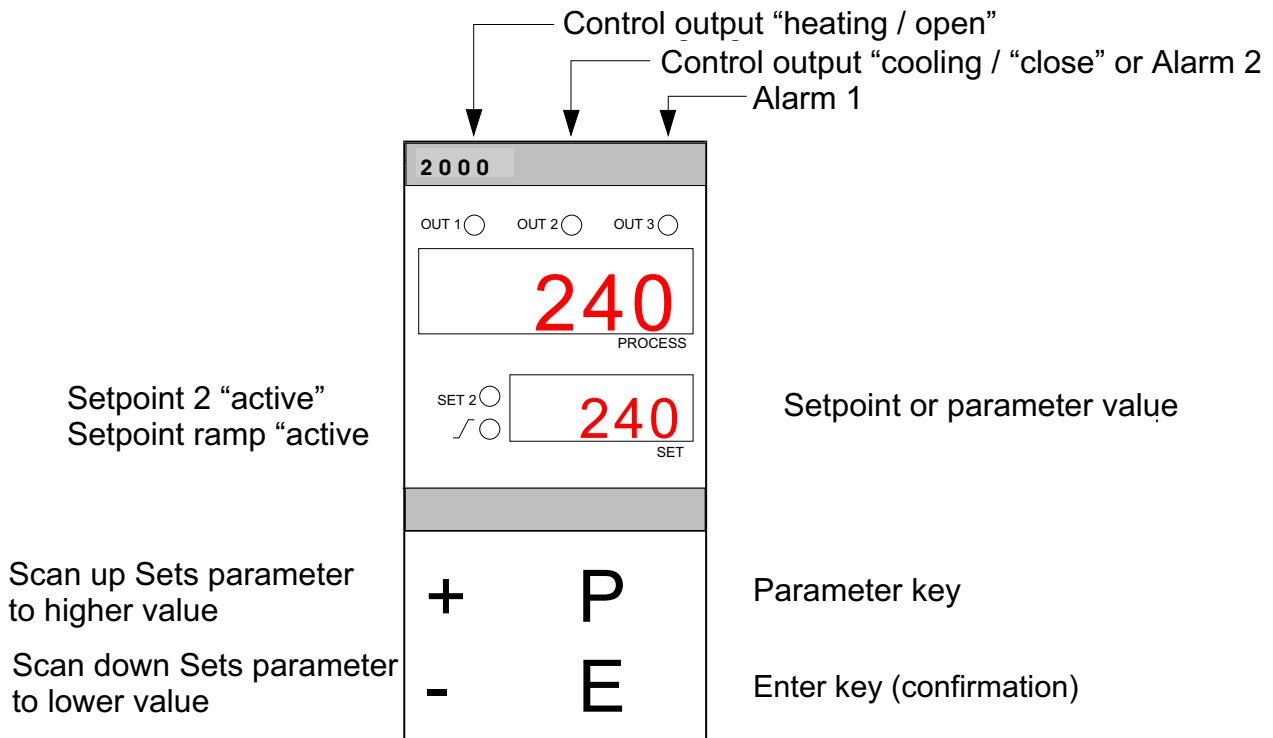

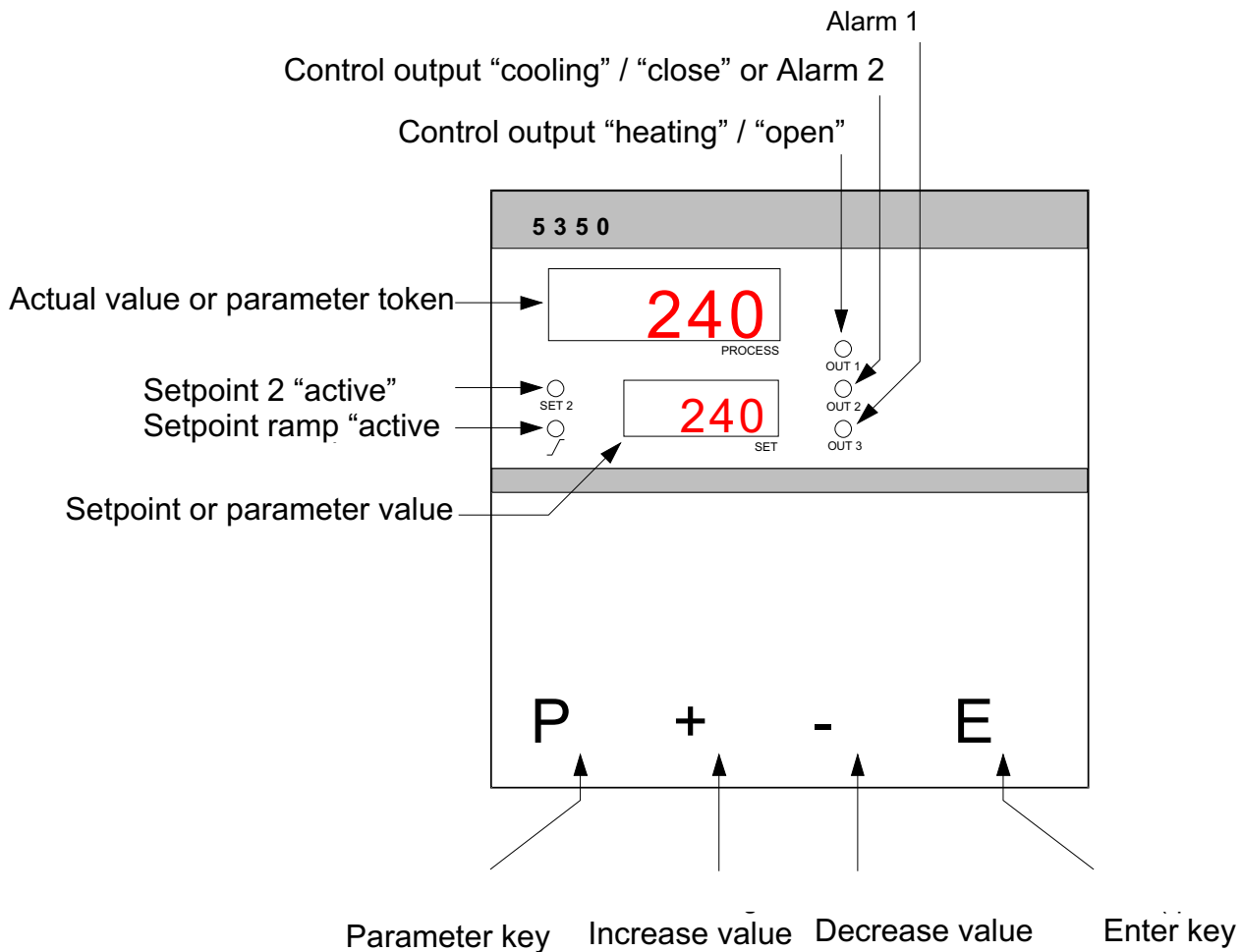

Adjustment of parameter values

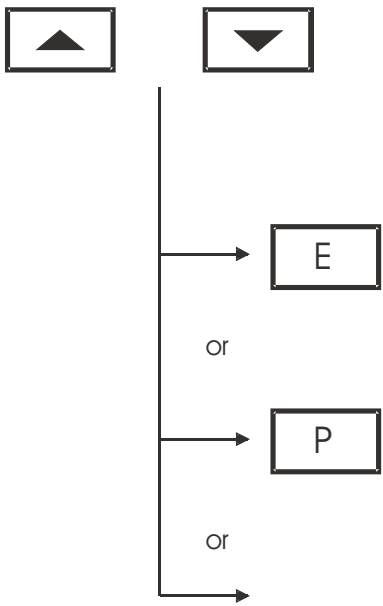

Adjustment of chosen parameter to lower or higher setting. Short operation = single-step adjustment, longer operation = quick-scan. When the parameter adjustments have been altered but not entered, the display will flash bright/dark.

Confirmation of the pre-selected value and storage with powerfail protection. Four decimal points appear briefly as a control of this function

Sets the parameter back to the originally stored value.

Any alteration made to the parameter, that is not confirmed (Enter_{or} key) within approx. 30 seconds, is not accepted and the parameter returns to its originally stored value.

Function levels

The operation of the controller is divided into three levels.

- Operating level
- Parameter level
- Configuration level

Two seconds after switching on the unit, the controller is automatically in the operating level.

Within the **operating level** the set-points, the set-point ramp and the alarm values can, in succession, be displayed by pressing P and adjusted by pressing the + and -keys.

Within the **parameter level** the values are adjusted to suit each individual process. This level is reached by simultaneously pressing the P and E keys.

Within the **configuration level** the controller type, input type, range, alarm behaviour and output type can be pre-selected. This primary information has to be entered before taking the controller into operation. The configuration level is reached by simultaneously pressing the P and E keys for a period of approx. 5 seconds.

The display of each single parameter within the parameter and configuration levels, and their adjustment, are made in the same fashion as within the operating level. After either pressing the E key for approx. 1 second, or waiting for a period of approx. 30 sec., the unit returns automatically to the operating level (display of process and set-point values).

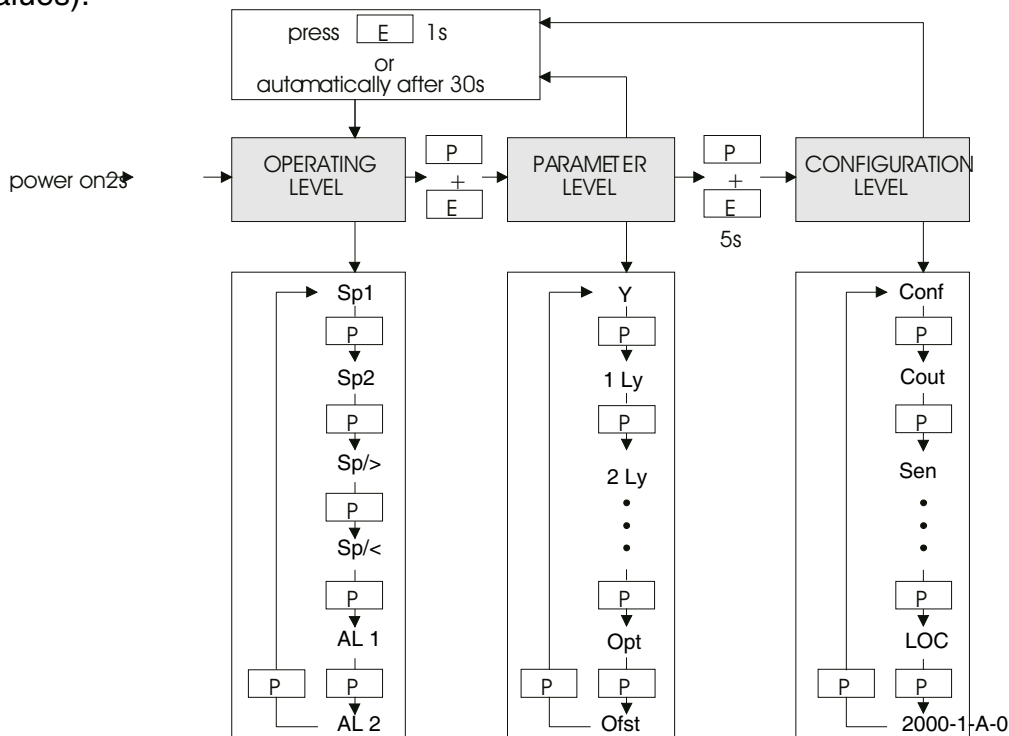

The values on the following pages, included in braces, apply only to controllers equipped with a serial interface.

For more details look at the separate interface description.

| Configuration level | | | |
|--|--|---------------------------------------|--|
| Display "Process" | Parameter | Parameter display "Set" [ex works] | |
| C o n F | controller configuration { 80H, 8H, r/w } | 2 P h | 2-point or continuous controller: "heating" |
| | | 2 P c | 2-point or continuous controller: "cooling" |
| | | 2 P n c | 2-point or continuous controller: "cooling, non linear characteristic line" *) |
| | | 3 P | 3-point-controller: "heating - off - cooling" |
| | | 3 P n c | 3-point-controller: "heating - off - cooling, cool with non-linear characteristic line" *) |
| | | 3 P S t | 3-point-step-controller: "open - neutral - close" |
| <p>*) non-linear cooling: For cooling a "cooling"-control rating with linear or non linear characteristic line (e. g. evaporative cooling from water) can be chosen.</p> | | | |
| | | | |

| | | | | |
|----------|--|---|------------------|------------------|
| C O u t | Configuration of Outputs { 81H, 8H, r/w } | OUT 1 (control-output) und OUT 2 (control- or alarm-output A2) | | |
| | | | OUT1: | OUT2: |
| | | | Relay | Relaiy |
| | | i r 2 r | bistable | Relay |
| | | i b 2 r | 0...20mA/0...10V | Relay |
| | | i c 2 r | 4...20mA/2...10V | Relay |
| | | i c . 2 r | Relay | bistable |
| | | i r 2 b | bistable | bistable |
| | | i b 2 b | 0...20mA/0...10V | bistable |
| | | i c 2 b | 4...20mA/2...10V | bistable |
| | | i c . 2 b | Relay | 0...20mA/0...10V |
| | | i r 2 c | Relay | 4...20mA/2...10V |
| | | i r 2 c. | bistable | 0...20mA/0...10V |
| | | i b 2 c | bistable | 4...20mA/2...10V |
| i b 2 c. | | | | |

Configurations level

| display "Process" | parameter | Adjustment range display "Set" <i>[ex works]</i> | | |
|----------------------|--|---|----------------------|-------------------|
| S E n | sensor-configuration { 1AH, 1H, r/w } | P 1 ° C | Pt 100, | -50,0...100,0 °C |
| | | P 1 ° F | Pt 100, | -58,0...212,0 °F |
| | | P 2 ° C | Pt 100, | -90,0...205,0 °C |
| | | P 2 ° F | Pt 100, | -130,0...401,0 °F |
| | | P 3 ° C | Pt 100, | -199...100 °C |
| | | P 3 ° F | Pt 100, | -326...212 °F |
| | | P 4 ° C | Pt 100, | 0...400 °C |
| | | P 4 ° F | Pt 100, | 32...752 °F |
| | | P 8 ° C | Pt 100, | 0...800 °C |
| | | P 8 ° F | Pt 100, | 32...1472 °F |
| | | L 4 ° C | TC Fe-CuNi (L), | 0...400 °C |
| | | L 4 ° F | TC Fe-CuNi (L), | 32...752 °F |
| | | L 8 ° C | TC Fe-CuNi (L), | 0...800 °C |
| | | L 8 ° F | TC Fe-CuNi (L), | 32...1472 °F |
| | | J 8 ° C | TC Fe-CuNi (J), | 0...800 °C |
| | | J 8 ° F | TC Fe-CuNi (J), | 32...1472 °F |
| | | t 4 ° C | TC Cu-CuNi (T), | 0...400 °C |
| | | t 4 ° F | TC Cu-CuNi (T), | 32...752 °F |
| | | E 7 ° C | TC NiCr-CuNi (E), | 0...700 °C |
| | | E 7 ° F | TC NiCr-CuNi (E), | 32...1292 °F |
| | | n 1 ° C | TC NiCr-Ni (K), | 0...1200 °C |
| | | n 1 ° F | TC NiCr-Ni (K), | 32...2192 °F |
| | | 5 1 ° C | TC Pt10Rh-Pt (S), | 0...1600 °C |
| | | 5 1 ° F | TC Pt10Rh-Pt (S), | 32...2912 °F |
| | | r 1 ° C | TC Pt13Rh-Pt (R), | 0...1600 °C |
| | | r 1 ° F | TC Pt13Rh-Pt (R), | 32...2912 °F |
| | | 0 - 20 | current DC 0...20 mA | |
| | | 4 - 20 | current DC 4...20 mA | |
| | | 10 d c | voltage DC 0...10 V | |

If the input configuration is changed, the following parameters are all reset (setting in brackets), and need to be re-adjusted: Set-points (OFF); Ramps (OFF); Alarms (OFF); control sensitivity (0); sensor offset value (OFF); lower set-point limit (min: display range bottom end); upper set-point limit (max: display range top end).

| | | |
|---------|---|---|
| C O N P | Configuration of compensation point { 03H, 0H, r/w } | int ; 0...60 °C <i>[int]</i> int ; 32...140 °F |
|---------|---|---|

Adjustment of used compensation point. If an external compensation point is in use, the appropriate temperature has to be set here. The adjustment has to be made in degree Celsius or in degree Fahrenheit according to the input configuration. This parameter is only available if input configuration is a thermocouple sensor

Configuration

| | | |
|----------------------|-----------|---|
| display "Process" | parameter | Adjustment range display "Set" [ex works] |
|----------------------|-----------|---|

The following parameters are only valid for standard signal inputs (DC 0-20 / 4-20 mA, DC 0-10 V). The difference between the bottom end of the display range and the top end must amount to a minimum of 100 units, and a maximum of 2000 units. By adjustment of one of the aboveparameters, the other will automatically follow in case of need.

| | | | |
|-------|--|--------------|----------------|
| r d P | decimal points { 1DH, 1H, r/w } | 0; 1; 2 | [1] |
| r H i | display range top { 1FH, 1H, r/w } | r Lo...9999 | [100,0] |
| r Lo | display range bottom end { 1EH, 1H, r/w } | -999 ...r Hi | [0,0] |

| | | | |
|---------|---|--------------------------|--------------|
| S P H i | upper setpoint limit { 2CH, 2H, r/w } | SPLo...Meßbereichsende | [400] |
| S P L o | lower set-point limit { 2BH, 2H, r/w } | Meßbereichsanfang...SPHi | [0] |

Configuration level

display parameter Adjustment range display "Set"
"Process" **[ex works]**

| | | | |
|---------|-------------------------------------|---------|--|
| C o A 1 | Alarm 1-config. { 34H, 3H, r/w } | OFF | Alarm OFF |
| | | _ _ - 1 | signal contact (SC) off-on |
| | | _ J - 2 | limit contact (LC) off-on |
| | | - N - 3 | limit comparator (LCP) off-on-off |
| | | - _ _ 4 | signal contact (SC) on-off |
| | | - L - 5 | limit contact (LC) on-off |
| | | - U - 6 | limit comparator (LCP) onn-off-on |
| | | N - 7 | limit comparator (LCP) off-on-off with start-up suppression |

Switching behaviour: Alarm output signal contact

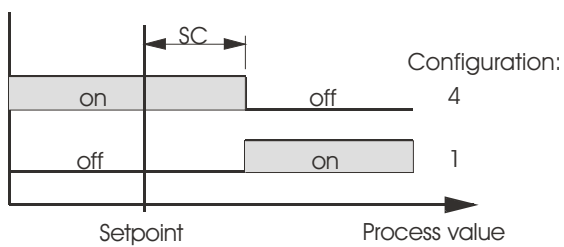

The signal contact is adjusted and displayed relative to the set-point.

Switching behaviour: Alarm output limit contact

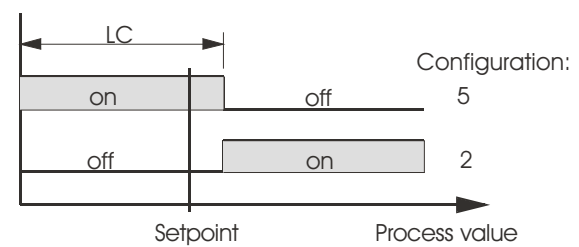

The limit contact is adjusted and displayed as an absolute value.

Switching behaviour: Alarm output limit comparator

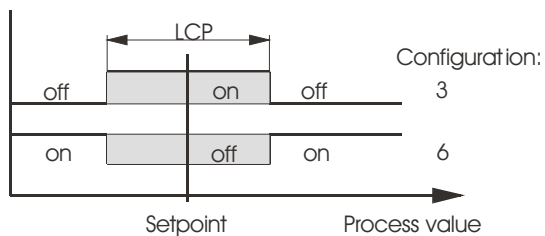

The limit comparator is adjusted and displayed relative to the set-point.
The selected value is effective below and above the set-point

on: Relay „activated“ or bistable voltage output „high“
off: Relay “non active” or bistable voltage output “low”

If a set-point ramp has been programmed, the alarms that are relative to the set-point (signal contact, limit comparator) follow the set-point up the ramp.

Switching behaviour: Alarm output limit comparator + start-up suppression

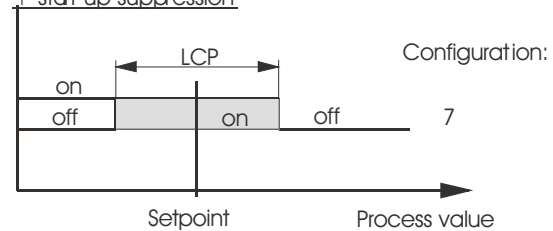

The alarm relay of the limit comparator with Start-up suppression is activated when the controller is first switched on. It is only then deactivated when the process value has been within, and left, the O.K. zone.

Please note: In case of sensor error the alarms react in the same way as range override. The alarm contacts therefore do not offer protection against all types of plant breakdown. With this in mind, we recommend the use of a second, independent monitor unit.

| | | |
|---------|---|----------------------------------|
| C o A 2 | Alarm configuration { 35H, 3H, r/w } | see CoA1 (Alarm 1-configuration) |
|---------|---|----------------------------------|

Configuration level

| | | |
|-------------------|-----------|------------------------------------|
| Display "process" | parameter | display "Set" [ex works] |
|-------------------|-----------|------------------------------------|

Only for 2-point controller (heating) -
or continuous controller (heating) -
or 3-point controller - configuration.

Soft start (general function):

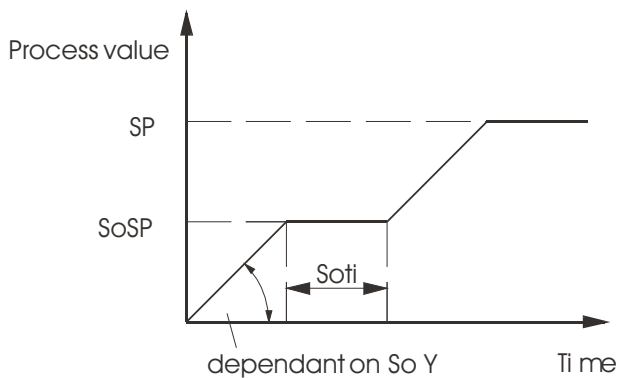

For this purpose the bistable voltage output of the controller must be chosen to actuate SSR relays.

During the soft start the controllers output response is limited to a pre-selected ration, in order to achieve as low baking out of high performance heat cartridges.

Simultaneously the output clock frequency is quadrupled. Once the process value reaches the soft start set point, it remains stable at this value for a pre-selected hold-duration time. At the end of this period the process value rises to the valid set-point.

This results in a slower, more regular heating period

If the soft start is active, the controllers autotune function cannot be operated.

If a set-point ramp has been programmed, the soft start has priority, and the ramp will only become active after the soft start has been completed.

The soft start cannot be selected if the controller is configured as a 3-point step controller.

| | | |
|--------|--|---|
| So y | output ratio { 6AH, 6H, r/w } | [OFF], 10...100%; OFF: soft start inactive, parameters SoSP and Soti of no importance |
| So S P | set-point { 6BH, 6H, r/w } | SPLo...SPHi [0] |
| So t i | hold duration time { 6CH, 6H, r/w } | [OFF]; 0,1...10,0 min |

| Configuration level | | |
|---|---|------------------------------------|
| display "process" | parameter | display "Set" [ex works] |
| H A n d | manual output ratio { 62H, 6H, r/w } | [OFF], Auto |
| <p>If manual operation is activated, an "H" is displayed as the first digit in the "set" display, followed by the valid output ratio. This ratio can be manually altered in steps of 1% (+ and -keys). The confirmation succeeds without of E. Setting: "OFF": non active (automatic operation)</p> <p>Setting "Auto": In event of sensor break the controller automatically maintains the last valid output ratio as the actuating signal. A few seconds after the sensor break has been rectified, the controller returns to automatic operation and calculates the required output ratio. An additional signal can be issued in the event of sensor break, if the alarm contacts are programmed accordingly.</p> <p>Setting "NAn": The controller now operates only as an actuator; the temperature control is no longer active..</p> <p>Achtung! By altering from controller operation to manual operation (Setting controller maintains the last valid output ratio as the actuating signal. Under the following circumstances, the output ratio is 0%:</p> <ul style="list-style-type: none"> - if the output ratio at time of sensor break was 100%, - if the controller is working along a set-point ramp, - if the control deviation was more than 0.25% of the total range at the time of sensor break, - if Xp = OFF - if the softstart was active at the time of sensor break. | | |

| This parameter is only available when the controller is configured as a 3-point Stepp controller. | | | |
|---|--|--------------------------------|---|
| C o 5 b | Behaviour in the event of sensor break { 8AH, 8H, r/w } | OFF o u t 2 o u t 1 | OUT 1 + 2 off OUT 1 off-, OUT 2 on OUT 1 on-, OUT 2 of |
| L O C | Security lock { 85H, 8H, r/w } | OFF P C - S P I A L L | lock inactive parameter- and conf.- level locked all parameters apart from set-point 1 locked all parameters locked |
| <p>All locked parameters can be selected and read, but not altered. This adjustment cannot be changed if the external switch S2 is dosed</p> | | | |

| Configuration level | | | |
|---|---|------------------------------------|---------------------------------|
| display "process" | parameter | display "Set" <i>[ex works]</i> | |
| The following parameter apply only to controllers equipped with a serial interface | | | |
| A d r | Unit address 1 255 { 8FH, 8H, r/w } | [1] | |
| <p>Using this adress, a host computer system can communicate with the controller. Every controller must have an individual address..</p> <p>Attention! A maximum of 32 controllers can be connected to a RS 485 bus.</p> | | | |
| B A u d | Baudrate {8DH, 8H, r/w } | O F F | serial interfaces off |
| | | 0. 3 | 300 Baud |
| | | 0. 6 | 600 Baud |
| | | 1. 2 | 1200 Baud |
| | | 2. 4 | 2400 Baud |
| | | 4. 8 | 4800 Baud |
| | | 9. 6 | 9600 Baud |
| | | 19. 2 | 19200 Baud |
| | | 38. 4 | 38400 Baud |
| <p>The Baud-rate displays the data transfer speed, with which one bit is transferred from the transmitter to the receiver. For further details please see the separate interface description.</p> | | | |
| F o r | Data format { 8EH, 8H, r/w } | 7 E 1 | 7 data, even, 1 stop bit |
| | | / o 1 | 7 data, odd, 1 stop bit |
| | | 7 E 2 | 7 data, even, 2 stop bits |
| | | 7 o 2 | 7 data, odd, 2 stop bits |
| | | 7 n 2 | 7 data, none, 2 stop bits |
| | | 8 E 1 | 8 data, even, 1 stop bit |
| | | 8 o 1 | 8 data, odd, 1 stop bit |
| | | 8 n 1 | 8 data, none, 1 stop bit |
| | | 8 n 2 | 8 data, none, 2 stop bits |
| <p>With this parameter the data format is determined. For further details see the separate interface description</p> | | | |
| 5 3 1 0 | Figure of device family { 01H, 0H, r } | - - - - | end of the config. level |

| parameter level | | |
|--|--|---------------------------------|
| The following parameters apply to 2-point and heat-cool controller configuration | | |
| display "process" | parameter | display "Set" <i>[ex works]</i> |
| Y | Valid output ratio { 60H, 6H, r } The output ratio display shows the momentarily calculated output ratio. It cannot be altered. The display is in percent of the installed performance capability for heating or cooling. Output ratio for cooling is shown as a negative value.. | -100...100 % |
| I L y | OUT 1-output ratio limit { 64H, 6H, r/w } | 0...100 % [100] |
| 2 L y | OUT 2- output ratio limit { 69H, 6H, r/w } (only by heat-cool-controller configuration) A limitation of the output ratio is only necessary when: -the heating energy supply is grossly over-dimensioned compared to the power required, or -to turn off a control output (setting: 0 %). Under normal circumstances no limitation is needed (setting: 100 %). The limitation becomes effective, when the controllers' calculated output ratio is greater than the maximum permissible (limited) ratio. Attention! The output ratio limitation does not work during autotuning | 0...100 % [100] |
| I P | OUT 1-Xp Prop.range { 40H, 4H, r/w } If Xp = OFF, the next parameter to follow ist (control sensitivity) | OFF; 0,1...100,0 % [3,0] |
| I d | OUT 1-Tv D-Anteil { 41H, 4H, r/w } | OFF; 1...200 s [30] |
| I J | OUT 1-Tn I-Anteil { 42H, 4H, r/w } INormally the controller works using PID control action. This means, controlling without deviation and with practically no overshoot during start-up. Control action can be altered in its structure by making the following adjustments to the parameters a. no control action, on-off (setting : Xp = OFF) b. P-action (setting: Tv und Tn = 0) c. PD-action (setting: Tn = 0) d. PI-action (setting: Tv = 0) e. PID-action | OFF; 1...1000 s [150] |
| I C | OUT 1-cycletime { 43H, 4H, r/w } The switching frequency of the actuator can be determined by adjusting the cycle time. This is the total time needed for the controller to switch on and off once. a) Relay outputs: cycle time > 10 s b) Bistable outputs 0,5...10 s. | 0,5...240,0 s [15,0] |

| parameter level | | | |
|----------------------|---|---|--------------------------|
| display "process" | parameter | display "Set" <i>[ex works]</i> | |
| I 5 d | Adjustment of the control sensitivity output OUT 1 (only if Xp = OFF, no control action) sensitivity Sd { 47H, 4H, r/w } | OFF; 0,1...80,0 OFF; 0,01...8,00 OFF; 0,001...0,800 | [0,1] 1) 2) |
| | | | |

| The following parameters apply only to the configuration of heat-cool controllers | | | |
|---|---|---|--------------------------|
| S h | Switch point interval { 46H, 4H, r/w } | OFF; 0,1...80,0 OFF; 0,01...8,00 OFF; 0,001...0,800 | [OFF] 1) 2) |
| | This parameter raises the set-point (switch-point) for the cooling output by the displayed value. It can help to reduce the switching frequency between the heating and cooling outputs, if this is too high. Simultaneous activation of the heat and cool outputs is not possible. | | |

| | | | |
|------|--|---|--------------------------|
| 2 P | OUT 2-Xp cool P-range { 50H, 5H, r/w } | OFF; 0,1...100,0 % | [6,0] |
| | If Xp = OFF, the next parameter to follow is (contr. sensitivity for OUT 2). | | |
| 2 d | OUT 2-Tv { 51H, 5H, r/w } | OFF; 1...200 s | [30] |
| 2 J | OUT 2-Tn { 52H, 5H, r/w } | OFF; 1...1000 s | [150] |
| 2 C | OUT 2 cycletime { 53H, 5H, r/w } | 0,5...240,0 s | [15,0] |
| 2 Sd | Adjustment of the control sensitivity OUT 2 (nur wenn Xp = OFF, ohne Rückführung) Schaltdifferenz Sd { 57H, 5H, r/w } | OFF; 0,1...80,0 OFF; 0,01...8,00 OFF; 0,001...0,800 | [0,1] 1) 2) |

1) Valid for ranges with a mantissa of one digit
2) Valid for Ranges with a mantissa of two digits

| Parameter level | | | |
|--|---|---|--------------------------|
| display "process" | parameter | displa "Set" [ex works] | |
| The following parameters apply only to the configuration of 3-point step controllers | | | |
| | | | |
| <p>3-point step controllers use PI control action in combination with motor actuators. It is important, that Sh should be several times larger than Sd. Switching frequency is dependant on the pre-selected feedback values..</p> | | | |
| P | Xp { 40H, 4H, r/w } | OFF; 0,1...200,0 % | [10,0] |
| t S | Motor actuating time { 41H, 4H, r/w } | 5...800 s | [40] |
| t n | set time { 42H, 4H, r/w } | 0,5...80,0 min | [3,0] |
| S d | Control sensitivity { 47H, 4H, r/w } | OFF; 0,1...80,0 OFF; 0,01...8,00 OFF; 0,001...0,800 | [0,1] 1) 2) |
| S h | Switch-point interval { 46H, 4H, r/w } | OFF; 0,1...80,0 OFF; 0,01...8,00 OFF; 0,001...0,800 | [0,1] 1) 2) |

- 1) Valid for ranges with a mantissa of one digit
- 2) Valid for ranges with a mantissa of two digits

Parameter level

display
"process"

parameter

display "Set"
[ex works]

O P t

Autotune
{ 88H, 8H, r/w }

[OFF]

Autotuning not active

on single autotune cycle, upon command

Auto

automatic triggering of the auto-tune every time the controller is switched on, if the momentary difference between the set-point and the process value is larger than 7% of the total range.

The tuning algorithm determines the characteristic values within the controlled process, and calculates the valid feedback parameters (X_p , T_n , T_n) and the cycle time ($C = 0.3 \times T_v$) of a PD/I controller for a wide section of the range

If the controller is used as a heat-cool controller, the determined parameters for heating are also adopted for cooling. Here though the value of X_p -range for cooling is doubled..

Autotuning activates during start-up shortly before the set-point is reached. The setpoint must amount to at least 5 % of the total range. If activated after the set-point has already been reached, the temperature will first drop by approximately 5 % of the total range, in order to detect the exact amplification of the process. The tuning algorithm can be activated at any time by selecting the option Opt=on and pressing E. An adjust of output ratio limit is not considered.

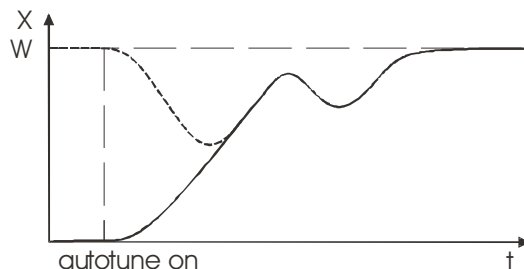

The optimization is time limited to 2 hours. If no usable control parameter are found, the optimization is stopped.

- if soft-start is active
- if the controller is in manual operation or
- if a sensor break occurs.

OFF5 process value
{18H, 1H r/w}

OFF ; -999.1000

COFFJ

OFF; -99,0...100,0

1)

OFF ; -9,99...10,00

2)

This parameter serves to correct the input signal, e.g. for:

- the correction of a gradient between the measuring point and the sensor tip;
- line resistance balancing of 2-line Pt100 (RTD) sensors;
- correction of the control deviation when using P or PD action.

If for example the offset value is set to +5 °C, then the real temperature measured by the sensor (when the process is balanced) is 5 °C less than the set-point and the displayed process values.

Operating level

| | | |
|----------------------|-----------|------------------------------------|
| display "process" | parameter | display "Set" [ex works] |
|----------------------|-----------|------------------------------------|

| | | | |
|----------------------------------|-------------|----------------------------|------------|
| ProcessValue { 21H, 2H, r/w } | set-point 1 | <i>OFF, SP1L...SP1H</i> 4) | [0] |
|----------------------------------|-------------|----------------------------|------------|

Basic operating positions

If set-point 1 is set to "OFF..", the controller switches to stand-by. The set display then shows "OFF". All main outputs are switched off, and the alarms are deactivated.

All parameters can be displayed and altered during stand-by.

Attention! Altering between control operation and manual operation is available by simultaneously pressing the + and - keys for a period of approximate two seconds. This adjustment is not stored with powerfail protection.

Only applicable to 3-point Stepp controller configuration

| | | | |
|-------------|------------------|----------------|--------------|
| <i>HAND</i> | Manual operation | <i>OFF, ON</i> | <i>{OFF}</i> |
|-------------|------------------|----------------|--------------|

{ 8CH, 8H, r }

OFF: Normal control operation of the unit.

ON: The unit now works only as an actuator.

The first parameter shown in the process display of the operating level is the momentarily valid process value. The word "Hand" appears in the set display (instead of the set-point). The outputs can now be manually activated by pressing either the + key (for OUT 1) or the – key (for OUT 2)

The next parameter to appear is "SP 1", the set-point. This set-point has no influence while the controller is being operated manually, although it can be adjusted for later application.

| | | | |
|------------|------------|----------------------------|--------------|
| <i>SP2</i> | Sollwert 2 | <i>OFF; SP2L...SP2H</i> 4) | <i>{OFF}</i> |
|------------|------------|----------------------------|--------------|

{ 22H, 2H, r/w }

The second set-point is active when the external contact S1 is closed. The corresponding LED on the front panel lights up, and the second set-point is shown in the display.

Please note, that the value of the second set-point cannot be changed in the basic operating position of the level. In order to change the value the parameter SP2 has to be selected.

Operating level

display "process" parameter display "Set"
[ex works]

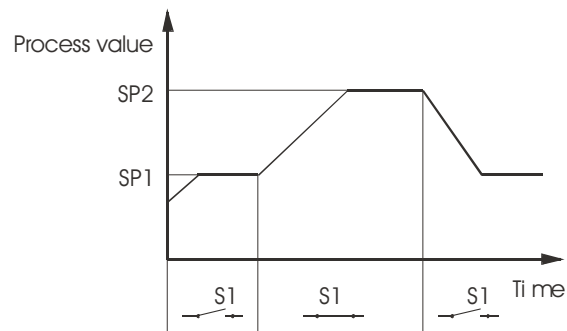

A programmed ramp is always activated when the set-point is altered or when the main supply is switched on.

The ramp constructs itself out of the momentary process value and the preselected set-point. If the ramp is active the corresponding LED lights up on the faceplate. The ramp can be activated for both set-point 1 and set-point 2.

By programming the second set-point accordingly a set-point profile can be obtained (please see example above).

If a set-point ramp has been programmed, the soft start has priority, and the ramp will only become active after the soft start has been completed.

| | | | |
|-------------|---|---|----------------------------|
| <i>SP</i> | Rising ramp {2FH, 2H, r/w } | <i>OFF</i> ; 0,1...100,00 units./min <i>OFF</i> ; 0,01...10,00 units./min <i>OFF</i> ; 0,001...1,000 units./min | { <i>OFF</i> } 1) 2) |
| <i>SP</i> | Falling ramp { 2DH, 2H, r/w } | <i>OFF</i> ; 0,1...100,0 units./min <i>OFF</i> ; 0,01...10,00 units./min <i>OFF</i> ; 0,001...1,000 units./min | { <i>OFF</i> } 1) 2) |
| <i>RL 1</i> | Alarm 1 { 38H, 3H, r/w } | Signal contact <i>OFF</i> ; -999...1000 <i>OFF</i> ; -99,9...100,0 <i>OFF</i> ; -9,99...10,00 | { <i>OFF</i> } 1) 2) |
| | | Limit comparator <i>OFF</i> ; 1...1000 <i>OFF</i> ; 0,1...100,0 <i>OFF</i> ; 0,01...10,00 | 1) 2) |
| | | Limit contact <i>OFF</i> ; bottom end to top end range | |
| | The range of adjustment is dependent on the sensor and the alarm configuration. Both have to be set in the configuration level. | | |
| <i>RL 2</i> | Alarm 2 { 39H, 3H, r/w } | for adjustments see Alarm 1 | |
| | The alarm 2 is only available if the controller is programmed as a 2-point or continuous controller in the configuration level. | | |

1) Valid for ranges with a mantissa of one digit

2) Valid for ranges with a mantissa of two digits

Hints for using the serial interface

The following parameters apply only to controllers equipped with a serial interface

Status word 1 reports errors or alarm states ascertained by the controller.

| | | |
|-------------------------------|------------|--|
| Status word 1 {70H, 7H, r} | Bit 0 = 1: | System error |
| | Bit 1 = 1: | Sensor error |
| | Bit 2 = 0: | no function |
| | Bit 3 = 1: | reset-control A reset was triggered during operation. The controller automatically resets bit 3 to 0 once status word 1 has been read by the computer |
| | Bit 4 = 0: | No function |
| | Bit 5 = 1: | Alarm 1 triggered |
| | Bit 6 = 1: | Alarm 2 triggered |
| | Bit 7 = 1: | Set-point ramp active |

Status word 2 gives an overview of the operating state of the controllers. The computer can specify different operating states for the controller. If status word 2 is manipulated by the computer, bit 0 must always be set to '1' (remote controller operation). The controller remains then in remote operation.

Exception: controller ON/OFF can also be edited in local operation.

If the controller is switched back to local operation by the computer, bit 0 of the status word 2 may only be edited

| | | |
|---------------------------------|------------------|--------------------------------------|
| Status word 2 {78H, 7H, r/w} | Bit 0 = 0: | controller operation remote or local |
| | 1: | controller operation remote |
| | Bit 1 = 0: | automatic mode (controller mode) |
| | 1: | manual mode (actuator mode) |
| | Bit 2 = 0: | autotune off |
| | 1: | autotune on |
| | Bit 3 = 0: | controller switched off |
| | 1: | controller switched on |
| Bit 4 = 0: | no function | |
| Bit 5 = 1: | setpoint 1 valid | |
| Bit 6 = 1: | setpoint 2 valid | |
| Bit 7 = 1: | no function | |

Attention!

Status word 2 cannot be stored with powerfail protection. An eventual 'power off' can be checked via bit 3 (status word 1). Afterwards status 2 must be set again.

The selection of the valid setpoint via interface is only done in remote operation. In case of local operation the selection is controlled via the external contact S1.

Status word 2 is available for reasons of compatibility with older devices.

We, however, recommend the application of appropriate individual parameters 8B H, 88 H, 21 H and 22 H.

Process value output: (as casting-device)

Corresponding to the process value the controller generates a scalable signal (0/4...20mA; 0...10V) which is available on the terminals 21/22 (13/14 by 5350).

Technical data

- **Process value output**

Output type (current or voltage) is determined automatically, dependent on load.

DC 0/4...20 mA, (load of ? 500 Ohm)

DC 0/2...10 V, (load of ? 1 k-Ohm)

linearity: < 1,5 %

delay: ca. 2 s

The second alarm is unapplicable.

Parameter „CORZ“ und „RLZ“ are omitted.

The configuration of OUT 1 and OUT 2 in the configuration level is modified.

Note: now OUT 1 and OUT2 cannot be used as a continuous output

| | | | | |
|------------|--------------------------|--|--|--|
| <i>OUT</i> | configuration of outputs | <i>Ir2r</i> <i>ib2r</i> <i>ir2b</i> <i>ib2b</i> | OUT1: Relay bistable Relay bistable | OUT2: Relay Relay bistable bistable |
|------------|--------------------------|--|--|--|

Additional parameters in the configuration level:

| | | | |
|------|----------------------------------|-------------------------|---|
| PrcC | configuration of process outputs | 0-20 4-20 | 0...20mA / 0...10V 4...20mA / 2...10V |
| PrcH | output range; top end | PrcL...top range end | <i>[ex works: 400]</i> |
| PrcL | output range; bottom end | bottom range end...PrcH | <i>[ex works: 0]</i> |

The difference between the bottom end and top end must amount to a minimum of 100 units. By adjustment of one of the above parameters, there is automatic correction, if necessary.

Error messages

Errors during setting

| Display | Cause | Possible remedy |
|---------|--|------------------------------|
| S P L o | lower set-point limit has been reached | reduce limit, if necessary |
| S P H i | upper set-point limit has been reached | increase limit, if necessary |
| r L o | bottom range end has been reached (standard signal input) | reduce limit, if necessary |
| r Hi | top range end has been reached (standard signal input) | increase limit, if necessary |
| L O C | Parameter has been locked | unlock, if necessary |

Errors during control operation

| Display | Cause | Possible remedy |
|---------|---|---|
| H A n d | The controller has been programmed for manual operation. The unit has switched over to automatic owing to sensor defect | check sensor and cable |
| E r r 1 | Bottom range end has been exceeded, sensor defect | check sensor and cable |
| E r r 2 | Top range end has been exceeded, sensor defect | check sensor and cable |
| E r r 7 | auto tuning error | Extinguish error signal by pressing E. check auto tune conditions, restart. |
| E r r 8 | Data error | Extinguish error signal by pressing E, and check all parameters, If the error signal continues please send the controller back to the manufacturer for examination. |

Accessories for 2000-1-A-0 / 2000-1-B-0 (to be ordered separately)

Adapter for case size 96mm x 96mm, ¼ DIN

Panel cut-out: 92 mm x 92 mm
Controller size: 48 mm x 96 mm

Type: front-adapter from 96x96 mm to 48x96 mm
Order-No.: S0182-00000

Parameter list

| Operating level | | Parameter level | | Configuration level | |
|-----------------|--|-----------------|----------------|---------------------|----------------|
| SP 1 | | Y | not adjustable | ConF | |
| SP 2 | | 1 LY | | COut | |
| SP | | 2 LY | | SEn | |
| SP | | 1 P | | CONP | |
| AL 1 | | 1 d | | R dP | |
| AL 2 | | 1 J | | r Hi | |
| HAnd | | 1 C | | r Lo | |
| | | 1 Sd | | SPHi | |
| | | Sh | | SPLo | |
| | | 2 P | | CoA1 | |
| | | 2 d | | CoA2 | |
| | | 2 J | | So Y | |
| | | 2 C | | SoSP | |
| | | 2 Sd | | Soti | |
| | | P | | HAnd | |
| | | tS | | CoSb | |
| | | tn | | LOC | |
| | | Sd | | Adr | |
| | | Sh | | bAud | |
| | | OPt | | For | |
| | | OFSt | | 5310 | not adjustable |

Note! Depending on automatic controller configuration some parameters at the automatic controller are not available.

seli GmbH Automatisierungstechnik

Zentrale

Dieselstraße 13

48485 Neuenkirchen

Tel. 05973 / 9474-0

Fax 05973 / 9474-74

E-Mail Zentrale@seli.de

Internet <http://www.seli.de>



Automatisierungstechnik