

Retractable PH Redox-Holder

Manual

Type SAW-830



Contents

1	Security and safety measures	1
1.1	General Safety Information	1
1.2	Intended Use	1
1.3	Risk areas and residual risks	2
1.4	Utilities	2
1.5	Safety Device	3
1.6	Personal	3
1.7	Disposal	4
1.8	Symbols and pictograms	4
1.9	Safe use in hazardous areas	4
2	Product Description	6
2.1	Automatic Holder SAW	6
2.2	Process-Integration	7
3	Delivery	9
3.1	Scope of delivery	9
3.2	Check of the delivery	9
4	Assembly	10
4.1	Prepare Facility	10
4.2	Prepare Holder	10
4.3	Install Holder	10
4.4	Adjust Protection Cap	11
4.5	Install flush line	12
4.6	Pneumatic Hose	14
4.7	Install Sensor	15
5	Operation	17
5.1	Activate Holder	17
5.2	Automatic operation	17
6	Maintenance	18
6.1	Important Notes for Maintenance	18
6.2	Check media-touched seals	18
6.3	Remove Sensor	19
6.4	Unfasten pneumatic hose	19
6.5	Remove rinsing chamber with process connection	20

6.6	Change media touched seals	21
6.7	Remove immersion tube.....	24
6.8	Install immersion tube	25
6.9	Drive unit and rinsing chamber	26
6.10	Replace drive unit	27
6.11	Maintenance plan.....	28
6.12	Disposal	28
7	Help in a case of problem.....	29
7.1	Holder don't go from position "Service" to Pos. "Measure"..	29
7.2	Holder don't go from position "Measure" to Pos. "Service"..	29
7.3	Wrong Position Feedback	30
7.4	No Position Feedback	30
7.5	Sensor is often dirty	30
7.6	Sensor breaks often	31
7.7	On the control window escapes process fluid	31
7.8	On the control window streams out compressed air.....	31
8	Technical Data	32
8.1	Norms	32
8.2	Material properties	32
8.3	Flushing Connection	32
8.4	Sensors	33
8.5	Pneumatics	33
8.7	Ambient Conditions	33
8.8	Process Conditions SAW 830	34
8.9	Order Code	35
9	Parts and Accessories	35

1 Security and Safety Measures

1.1 General Safety Informations

The retractable holder SAW-830 is constructed in such way, that there is no danger, if the manual is read carefully.

- ▶ Please read the manual first.
- ▶ Install and operate the valve only if all instructions for safe and proper use have been read and understood.
- ▶ Keep the manual, so that you can always look up to
- ▶ Operate the holder and accessories in only perfect condition.
- ▶ Also regard the applicable laws, regulations, guidelines and standards in the countries and locations,

1.2 Intended Use

The retractable holder SAW-830 is mounted on tanks or pipelines. The pneumatic drive inserts a sensor into the process fluid to measure chemical or physical properties. This process is controlled automatically and can not be operated manually.

The choice of the material properties of the holder and equipment are determined by the process characteristics.

The holder must be serviced regularly

- ▶ Make a personalized maintenance plan for your process



- ▶ Perform only maintenance which are described in the manual
- ▶ Changes at the holders may be made only after consultation with the manufacturer.

The manufacturer is not liable for damages resulting from improper or incorrect use.

1.3 Risk areas and residual risks

The holder is connected to tanks and pipings, that can be under pressure. Process fluid can only escape by negligence and improper handling.

- ▶ Before you start and after every maintenance ensure that all seals and connections are complete and working.
- ▶ Don't loosen the screws of the lower and upper housing clip while the holder is working.
- ▶ Take appropriate protective measures, before touching the holder, because parts of it can take the temperature of the process.

1.4 Utilities

Use only tested and approved Utilities and accessories.

Seals

- ▶ Select the material properties of the process seal and the O-rings depending on the process fluid and the rinsing liquid.
- ▶ Consider the swellable and the acid or alkali resistance of sealing material.

- Sensor** ▶ Choose a suitable sensor and note the Detail in Chapter 8, "Technical data".
- compr. air** ▶ filter (40 mm), clean and deoiling of compressed air.
▶ Ensure that the pressure is between 4 and 6 bar.
- Spülflüssigkeit/
Reinigungsmittel** ▶ Choose a cleanser which is adapted for the process, holder and sealing materials and dispose it properly.

1.5 Safety installations

Pos. "Service" The retract protection prevents, that the immersion tube retracts into the process without sensor and thus process liquid escapes.

- ▶ You can only install or deinstall the sensor, if the holder is in position „Service“.
- ▶ You act negligently, if you to put the retract protection out of operation.

Pos. "Measure" When the sensor is in position of "measuring" it is sunk in the drive unit.

- ▶ You can´t remove the sensor
- ▶ You act negligently, if you try to remove the sensor while it is in position „Measure“!

Prot. Basket To protect the sensor from mechanical impact you can adjust the protection basket at the end of the immersion tube.

1.6 Personal

Qualification Only trained personnel should install the holder and do services!

Protection Clothes The operators have to wear safety glasses and suitable protective clothing. During the commissioning and maintenance work.

UVV You respect the applicable regulations and rules for working safety in the countries and locations.

1.7 Disposal

Observe the rules and regulations for waste disposal that are suitable in the countries and locations.

1.8 Symbols and Pictograms

In the manual icons and symbols are used for better orientation.

DANGER!



The security notice with the signal word DANGER indicates that you risk life and high material damage if you ignore the instructions!

ATTENTION!



The security notice with the signal word ATTENTION indicates that you risk high material damage if you ignore the instructions!



Here is an important note!



If you see this sign, then you have to do the working steps in the declared chronology.

1.9 Safe use in hazardous areas

For safe use in hazardous areas, the following points should be considered:

- ▶ The top drive unit is to protect against electrostatic charge. It may only be wiped with an antistatic cloth.
- ▶ For the medium wetted parts, which consist of non-conductive material, the electrostatic charge is taken into account. This applies particularly to non-conductive liquids
- ▶ The sensor must conform to the directive 94/9EG and the ambient temperatures has to be noticed.
- ▶ It is important to ensure that the movements, when moving in and out the sensor will not damage the connection.
- ▶ There are different temperature-classes of the particular materials to note.
- ▶ It is necessary to provide for a potential equalisation.

DANGER!



The ATEX - Certificate in section 10.1 does not apply to SAW 830. The holder may not be used in hazardous areas.

2 Product Description

2.1 Automatic retractable holder SAW-830

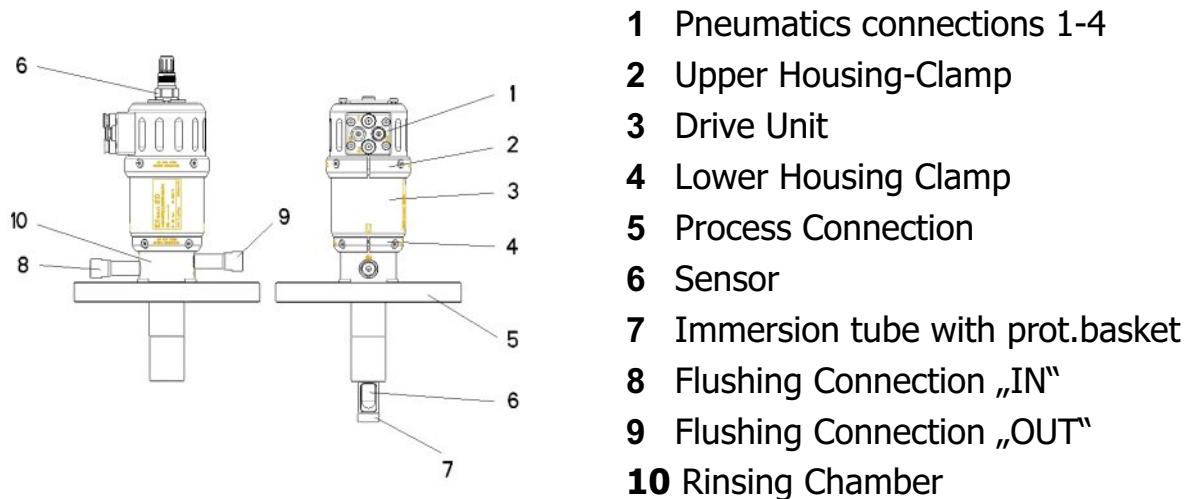

Fig. 1: Retractable Holder

Retractable holders are fastened with a suitable process connection on tanks or pipelines. In order to meet various process characteristics the retractable holder SAW-830 is made of high grade steel.

The holder SAW-830 is a pneumatically powered retractable holder with hygienic design, made of high-grade-steel for installation of Ø12mm-sensors on tanks or pipes.

- For all Ø12mm/225mm- and Ø12/280mm-sensors with thread PG13,5 (pH-glass- und ISFET-sensors, conductivity-, temperature-, turbidity- or optical sensors)
- Food Industry
- Pharmaceutical Industry
- Hygienic application
- With automatic cleaning and calibration of the sensor

Drive Compressed air is supplied through the pneumatic connections on the drive unit. The pneumatic actuator moves the immersion tube up to the maximum depth into the process medium. For safety, this is only possible with implemented sensor.

Messen When the final position of "Measuring" is reached, then the control receives a pneumatic position feedback. In this situation, the sensor head sunk into the drive unit and is not removable. The sensor measures the chemical and physical properties of the process fluid.

Service While the process is running, you can clean, rinse and calibrate the sensor. Therefore, the holder must be driven into position "Service". Here, too, a pneumatic position feedback is triggered when reaching the end position. In position "service" the immersion tube seals the flushing chamber from the process, to ensure that no process fluid escapes. The required liquid is fed in into the flushing chamber through the flushing connection "IN". After that it is derivated through the flushing connection "OUT".

2.2 Process-Integration

Steuerung For the operation of the retractable holder SAW-830 the automatical control can be installed. It is ideally suited to the functions of the holder.

Transmitter The retractable holder brings a sensor into the process fluid which transfers ist results to a transmitter.

PLS The external control and the transmitter can be connected to a process control system. Depending on the measurement results the measurement and rinsing intervals controlled automatically.

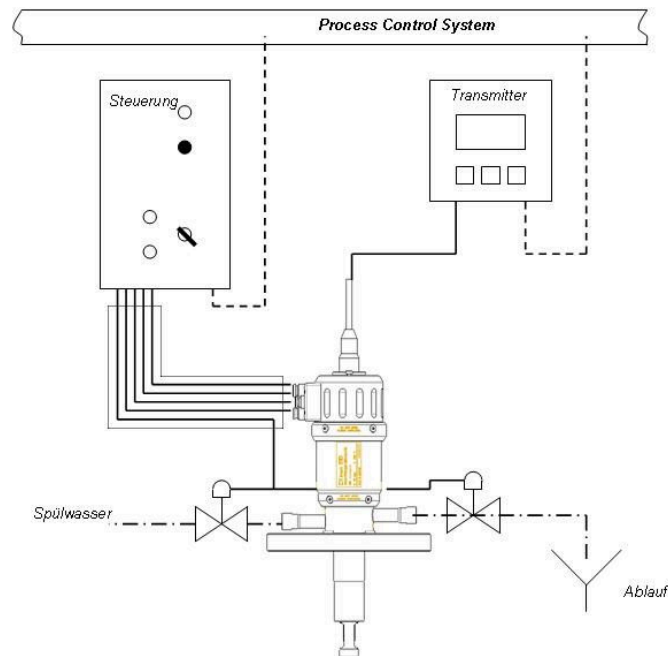

Figg. 2: Process Procedure

Pressure Temperature

For the selection of the appropriate holder, the pressure and temperature conditions of the process is essential. Depending on the temperature the holder made of high-grade-steel can be used with a pressure up to 16 bar and the plastic version will be used up to 10 bar. The process temperature must be between -10° and 140° C.



Note the pressure and temperature diagrams in Chapter 8!

Position of Installation

The holder can be operated in any position principally. In order to obtain reliable results, the properties of the selected sensor are relevant.

3 Delivery

3.1 Delivery Contents

The retractable holder is controlled in the factory and shipped ready for installation in a package that offers the best possible protection.

The delivery includes:

- Holder SAW
- Pin Wrench 2,5 mm
- 4 Spare Screws M4x8 (DIN 912)
- 2 Distance pieces for sensors
- Manual

You can get a material certificate optional.



Keep the holder in the box. There it is protected until installation at best.

3.2 Checking the delivery

Before you release the holder for installation, you must ensure that:



- Packaging and device are in perfect condition.
- The nameplate of the holder corresponds with the details of the order.

4 Assembly

4.1 Prepare Facility



Ensure that:

- ▶ that sufficient work space for the operation of the retractable holder exist
- ▶ the process is switched off
- ▶ tanks or pipings are pressure free, empty and clean
- ▶ flange and process connection of the holder are compatible
- ▶ the process seal is located on the mounting flange

4.2 Installing the holder



The holder must stand in position "service"!

- ▶ The immersion tube is completely in the flushing chamber.



Fig. 4: Position "service"

4.3 Installing the holder



First make sure that:

- ▶ The facility is prepared (chapter 4.1).

- ▶ The holder is prepared (chapter 4.2)

You install the holder in this way.

1. Position the retractable holder on the process seal
2. Tighten process connection firmly

4.4 Adjust Protection Basket

At the lower end of the immersion tube is a protective cage that can be aligned to the flow direction. The symbol on the cylinder of the drive unit shows the location of the opening in the immersion tube. Are the symbols parallel to the direction of flow, then the immersion tube is throughflowed completely. Are the symbols vertical to the flow, then the sensor is completely protected from incident flow. The immersion tube can be oriented in any position in between.

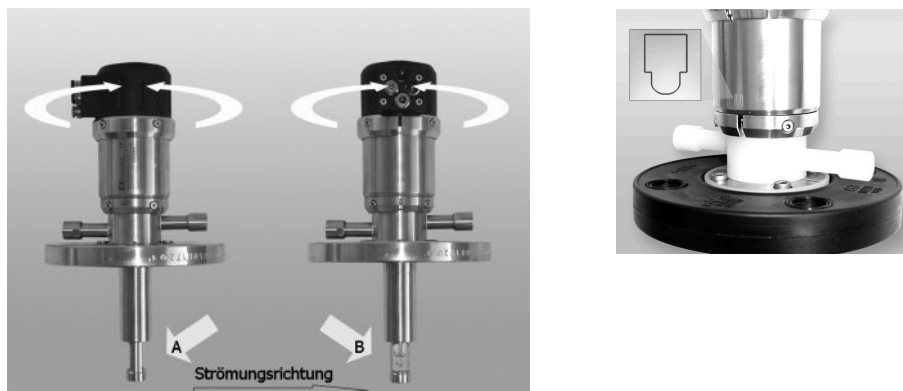

A Sensor maximal flow

B Sensor minimal flow

Fig.. 5: Protection Basket



Ensure that:

- ▶ the process is switched off
- ▶ tanks or pipings are pressure free, empty and clean
- ▶ No explosion - atmosphere is present

DANGER!



Process fluid leaks out, if you open the housing clamp while the process is still running

Burns or chemical burns, depending on status of the process fluid

- ▶ Power off the process!
- ▶ Pipes and containers must be depressurized

So you align the protection basket:

1. Loosen the screws of the lower housing clamp
2. Rotate drive unit and align symbol to flow
3. Tighten the screws of the lower housing clamp

4.5 Installing the Flush Line

The sensor can be flushed while the process runs. For this wash fluid must be triggered into the washing chamber and brought out. If the sensor should not be flushed, then the flush ports must be sealed with filler plugs.



A Flushing Connection „IN“

B Flushing Connection „OUT“

Fig. 7: Flushing connections

DANGER!**Process fluid escapes through open flushing connection**

Burns or chemical burns, depending on status of the process fluid

- ▶ You have to install flushing lines
or
- ▶ you must close the flushing connection „IN“ and „OUT“ with
filler plugs

DANGER!**When process-pressure is bigger than flushing pressure,**

then process fluid flows in the flushin lines while the holder goes in
position “service”

- ▶ On flush-connection “in” and “out” you need to install a
flush line with valve

ATTENTION!**If the pressure of flushing fluid is higher than 6 bar**

then holder and sensor can get damaged.

- ▶ Build in a pressure reducer if necessary

ATTENTION!**Polluted rinsing fluid**

can damage the holder

- ▶ Install a flush line with mud guard on the flushing connection “IN”

**So you install the flush-line:**

1. Install valve and mud guard in the flush line for intake of
rinsing fluid.
2. Fasten Flush line for the intake on the flush connection „IN“.
3. For expiration of the rinsing fluid install a valve into the flush line
4. Fasten flush line on the flush connection „OUT“ .
5. Check that all connections are tight.

So that the sensor is not dirty too quickly, the pressure of the rinsing liquid must come to at least 1 bar!

4.6 Installing Pneumatic Tubes

The retractable housing SAW-830 is powered with compressed air. On extension of the cylinders of the drive unit there are 4 air connections.



Fig. 8: Pneumatic Connections w 1-4

ATTENTION!



Escaping compressed air

can lead to property or personal damage

- ▶ Before feeding compressed air you need to ensure that the pneumatic tubes are tight.

ATTENTION!



Dirty compressed air

will damage the drive unit!

- ▶ Use filtered (one 40 mm), anhydrous and de-oiled compressed air



You need:

- ▶ 2 pneumatic tubes $\varnothing = 4$ mm
- ▶ 2 pneumatic tubes $\varnothing = 6$ mm

So you install the pneumatic tubes:

- ▶ For air supply "Position Service", plug pneumatic tube $\varnothing = 6$ mm in connector 1 (black)
- ▶ For feedback signal "Position Service", plug pneumatic tube $\varnothing = 4$ mm in connector 3 (black)
- ▶ For air supply of "position measure", plug pneumatic tube $\varnothing = 6$ mm in connector 2 (blue).
- ▶ For feedback signal „ Position Messen“, plug pneumatic tube $\varnothing = 4$ mm in connector 4 (blue).

4.7 Installing Sensor

In the retractable holder SAW-830 must be used. sensors with a diameter of 12 mm and a connection thread PG 13,5.

The length of the sensor depends on the type of the sensor and the selected holder



Notice the information in Chapter 8.4 "sensors"

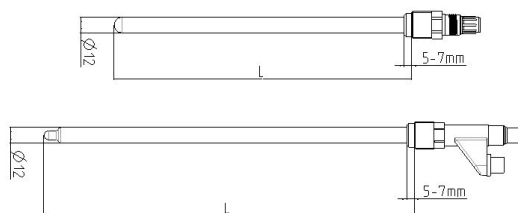

Fig. 9: Gel filled sensor (above) fluid filled sensor (below)

ATTENTION!



Too long sensors

can be destroyed when installing

- ▶ Check the sensor length before installation and use the supplied spacers if necessary.



Ensure that:

- ▶ the holder is in position „Service“.
- ▶ all seals are on hand that belong to the sensor
- ▶ the sensor is not longer than the allowed nominal length
- ▶ the sealing package is at least 5-7mm long.



Wrong!

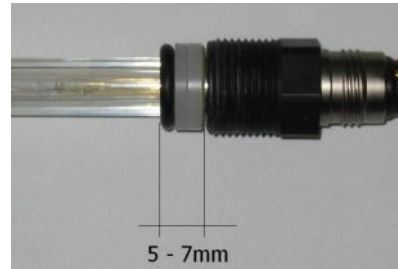

Right!

So you install the sensor:

1. install sensor and tighten firmly
2. position sensor cable

5 Operation

5.1 Put holder into operation

DANGER!



Risk of injury due to escaping process fluid

Burns or chemical burns, depending on property of the process fluid.

- ▶ Wear safety glasses and protection clothes.
- ▶ Check all seals and all connection of the holder before you power up the process.



Wear safety glasses and protection clothes when activating the holder.

Previously ensure that:

- ▶ Seals are complete and fully functional
- ▶ Sensor is installed and tightened firmly.
- ▶ Flushing connections are sealed with sifiller plug
or:
- ▶ Flush lines are installed and close.
- ▶ Pneumatics tube are installed and close.
- ▶ Protection cage is aligned correctly

5.2 Automatically Operation of the Holder



For the automatic operation of the retractable holder an external control is required.

Notice the functions of the pneumatic connections!

- ▶ Connection 1: Air supply position „service“.
- ▶ Connection 2: Air supply position „measure“.
- ▶ Connection 3: Feedback position “service“.
- ▶ Connection 4: Feedback position “measure“.

With the external control, you can drive the retractable holder from position "Service" in position "measurement" and back.

6 Maintenance

6.1 Important notes for maintenance

- ▶ Make a personalized maintenance plan for your process!
- ▶ Only qualified personnel authorized to perform service.
- ▶ Always wear suitable protective clothing during maintenance work.
- ▶ Only perform maintenance or repairs which are described in the instruction manual!
- ▶ Structural changes may be made only after consultation with the manufacturer.
- ▶ Before disconnecting the holder from the process, pipelines or containers must be free of pressure , empty and clean.
- ▶ Ex – atmosphere is not allowed

6.2 Check of medium touched seals

The retractable housing has a control window that lies between the lower housing clamps



Check regularly if the process control window is leaking fluid.



Fig. 10: Control window at the lower housing clamp

ATTENTION! Process fluid escapes at the control window!



Danger according to property of the process medium.

- ▶ Replace medium touched seals.
- ▶ Notice work instruction in chapter 6.6!

6.3 Remove Sensor



So you remove the sensor!

1. Drive the holder in position "service".
2. Strip off sensor cable.
3. Unfasten PG - screw.
4. Take out the sensor

DANGER! Broken glas-sensor!



The shards can damage the media touched seals.

- ▶ The medium touched seals must be checked and replaced if necessary.
- ▶ Notice work instruction in chapter 6.6!

6.4 Unfasten Pneumatic Tube



So you unfasten all four pneumatic tubes

1. Drive holder in position "service".
2. Turn off compresse air supply.
3. Depress plastic ring "A" on the pneumatic connection
4. Pull tube "B" simultaneously.

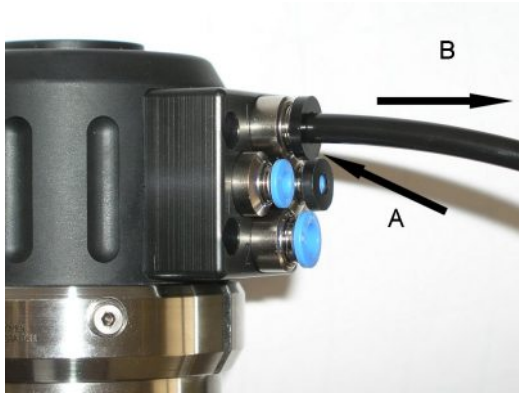

Fig. 11: Unfasten pneumatic tube

6.5 Remove Flushing Chamber with process connection

DANGER!



The facility is under pressure

Process fluid escapes when the holder is separated improperly from the process.

- ▶ Pipelines or containers must be pressure-free, empty, without ex-atmosphere and clean.



- ▶ Interrupt the process
- ▶ Make sure that the facility is depressurized, empty, without ex - atmosphere and clean.

So you remove the flushing chamber

1. Drive the holder into position "service"
2. Turn off compressed air supply

ATTENTION!



Escaping Compressed Air

can lead to property or personal damage.

- ▶ Turn off the compressed air supply before removing the pneumatic tubes

3. Loosen pneumatic tubes (Chapter. 6.4)

4. Remove sensor (chapter . 6.3)
5. Unfasten process connection.
6. Take out process seal and holder.
7. Unfasten screws of the lower housing clamps (Fig.10)
8. Disconnect flushing chamber with process connection "A" of drive unit "D"
9. Pull flushing chamber insert „B" from immersion tube „C"



- A** Flushing chamber with process connection
- B** Flushing chamber insert
- C** Immersion tube
- D** Drive unit

Fig. 12: Remove flushing chamber- and process connection

6.6 Change medium touched seal

DANGER!



The facility is under pressure.

Process fluid will escape when removing the holder from the process improperly.

- ▶ Previously make sure that the system is depressurized.
- ▶ Empty and clean pipes or tanks.
- ▶ Make sure that no ex - atmosphere exists

ATTENTION!



Escaping compressed air

can lead to property or personal damage.

- ▶ You must turn off the compressed air supply, before loosening the pneumatic tubes.



Install seals which are adapted to the holder and the process.

- ▶ Youse original parts only!

So change the seals:

1. Remove flushing chamber with process connection (Chapter. 6.5).
2. Remove and replace outer O-rings "A", "B", and inner O-ring "C" at the immersion tube.



**O-Rings
in [mm]
A 18,72 x 2,62
B 10,77 x 2,62**

Fig. 13: O-Rings at the immersion tube

"B" is cancelled

3. Remove and replace O-Rings "D" at the flushing chamber insert



**O-Ring
in [mm]
D 21,95 x 1,78**

Fig. 14: O-Rings on the flusching chamber insert

4. Remove PTFE-wiper "E" from flushing chamber
5. Remove and replace O-Ring "F"

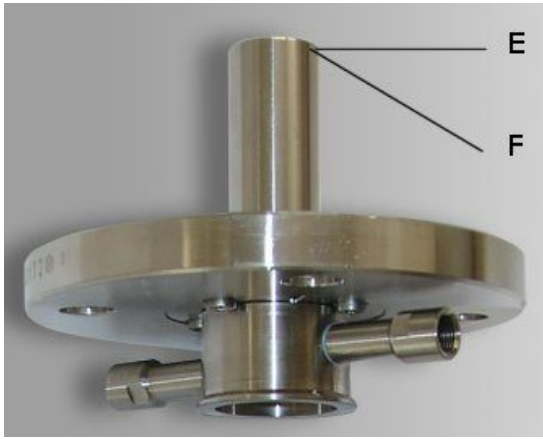

Wiper
in [mm]
E 19 x 6 x 1

O-Ring
in [mm]
F 21,89 x 2,62

Fig. 15: O-Rings / Wiper on the flushing chamber

6. Wiper E is reinstalled as follows:





Applies only to SAW-830 without PTFE wiper

7. Flushing chamber SAW-830 without wiper, replace O-Ring "H" and "I".



O-Ring
Ø in [mm]
H 21,95 x 1,78

I 18,77 x 1,78

6.7 Remove Immersion Tube

Danger!



The facility is under pressure

Process fluid will escape when removing the holder from the process improperly.

- ▶ Previously ensure that the facility is depressurized.
- ▶ Empty and clean pipes or tanks.

ATTENTION!



Escaping Compressed Air

can lead to property or personal damage.

- ▶ You must turn off the compressed air supply, before loosen the pneumatic tubes



So you loosen the immersion tube from the drive unit:

1. Remove flushing chamber and process connection (Kap. 6.5).
2. Remove the outer O-rings on the immersion tube (Fig. 13: "A" and "B").

3. Remove screws of the upper housing clamp.
4. Pull off cylinder "D" from the cylinder extension "A" (Fig. 18)

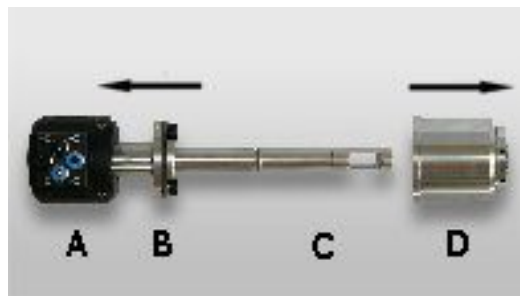

- A** Cylinder extension
- B** piston
- C** Immersion Tube
- D** Cylinder

Fig. 18: Remove cylinder

5. Loosen screw "E" and remove pins "F" (Fig. 19).

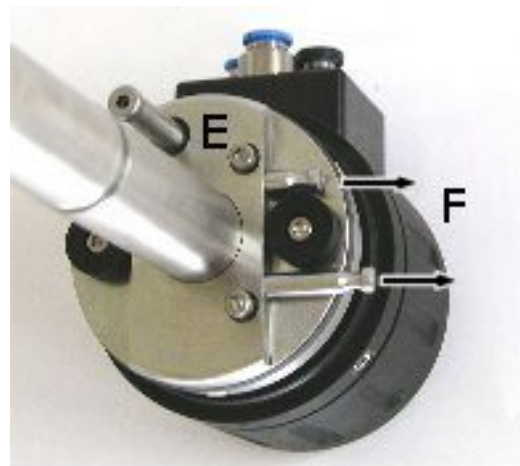

- E** 2 x M4 x 8
- F** 2 x pins

Fig. 19: Loosen fastener

6. Pull of immersion tube "C" from piston "B".

6.8 Install Immersion Tube



- The designations refer to Figure 18 and Figure 19 in Chapter 6.7. Remove immersion tube.

So you assemble immersion tube and drive unit:

1. Align grooves in the immersion tube „C“ to the piston „B“ and connect them
2. Apply pins „F“
3. Tighten screws „E“ firmly.
4. Grease inner wall of the cylinders „D“.
5. Push the cylinder „D“ over the immersion tube „C“.
6. Align the cylinder „D“ to cylinder-extension „A“.
7. Press together until the cylinder snaps in.
8. Put on upper housing clamp and tighten the screws firmly.
9. Apply O-Rings on the immersion tube (: „A“ and „B“).

6.9 Assemble Drive Unit and Rinsing Chamber

Ensure that

- all seals are installed and functional
- immersion tube and drive unit are combined (Chapter. 6.8)

So you install the rinsing chamber:

1. Push the rinsing chamber insert into the chamber until it snaps in.
2. Apply drive unit into the immersion tube.
3. Press together both parts firmly.
4. Align the drive unit until it snaps in the rinsing chamber.
5. Align protection cage (chapter. 4.4)
6. Put the lower housing clamp on and tighten firmly

Now the holder can be re-built into the process.

Notice the work instruction in chapter 4

- ▶ 4.3 Install holder
- ▶ 4.4 Align protection cage
- ▶ 4.5 Install flush line
- ▶ 4.6 Install pneumatic tubes
- ▶ 4.7 Build in sensr

6.10 Replace Drive Unit

DANGER!



The facility is under pressure

Process fluid will escape when removing the holder from the process improperly.

- ▶ Previously ensure that the facility is depressurized.
- ▶ Empty and clean pipes or tanks.
- ▶ Ensure that no ex-atmosphere exists

ATTENTION!



Escaping Compressed Air

can lead to property or personal damage.

- ▶ You must turn off the compressed air supply, before loosen the pneumatic tubes

Then you can insert the new drive unit:



First you must:

- remove the rinsing chamber with the process connection (chapt. 6.5)
- remove the immersion tube (chapter 6.8)
- clean if necessary cylinder, cylinder-extension, piston and housing clamp and dispose properly.

So you install the new drive unit:

1. Remove screws of the upper housing clamps.
2. Pull off cylinder "D" from the cylinder-extension "A" (Fig. 18)

3. Install immersion tube (chapter 6.8)
4. Drive unit and rinsing-chamber (chapter 6.9)

6.11 Maintenance Plan

Perform the maintenance at recommended intervals.

- | | |
|----------------------|--|
| weekly | <ul style="list-style-type: none">▶ Check medium touched seals (chapter 6.2)▶ Check processan connection▶ Check flush line▶ Check pneumatic connections |
| quarterly | <ul style="list-style-type: none">▶ Check screws of upper and lower housing clamps and tighten firmly. |
| yearly | <ul style="list-style-type: none">▶ Change medium touched seals (chapter 6.6)▶ Remove immersion tube and check it (chapter 6.7) |
| every 3 years | <ul style="list-style-type: none">▶ Replace drive unit (chapter 6.10) |

6.12 Disposal

- | | |
|------------------|--|
| Holder | Make sure that the holder is free of hazardous and toxic substances. According to the material you need to dispose the parts separately. Notice the rules and regulations for waste disposal that are valid in the countries and location. |
| Packaging | The packaging is made of cardboard and can be disposed as waste paper. |

7 Help in a Problem Case

Follow the instructions and warnings in the specified chapters.

7.1 Holder does not move from position "service" in position "measurement"

Possible Cause	Remedy
No compressed air present	Check pneumatic tubes (chapt. 6.4, 4.6)
Pressure is too low	Pressure must be between 4 and 6 bar (chapter. 4.6)
Sensor is missing	Install sensor (chapter. 4.7)
Sensor is loose	Tighten sensor firmly (chapter. 4.7)

7.1 Holder does not move from position "measurement" in position "service"

Possible Cause	Remedy
No compressed air present	Check pneumatic tubes (chapt. 6.4, 4.6)
Pressure is too low	Pressure must be between 4 and 6 bar (chapter 4.6)
Immersion tube or protection cage is blocked.	Prepare facility (chapter.4.2) Holder stays in position "measurement" Remove rinsing chamber with process connection (chapter 6.5) Replace drive unit (chapter 6.10)

7.3 Wrong Position-Feedback

Possible Cause	Remedy
Pneumatic tubes are connected falsely	Check pneumatic tubes (chapt. 6.4, 4.6)

7.4 No Position-Feedback

Possible Cause	Remedy
No compressed air present	Check pneumatic tubes (chapt. 6.4 4.6)
Pressure is too low	Pressure must be between 4 and 6 bar (chapter 4.6)
Drive unit is defect	Replace drive unit (chapter 6.10)

7.5 Sensor polluted often

Possible Cause	Remedy
Flushing lines are installed falsely	Check flushing lines (Kap. 4.5)
Pressure of rinsing fluid is too low Rinsing chamber is blocked	Increase rinsing pressure Pressure must be between 1 and 4 bar (chapter. 4.6)
Rinsing fluid is not suitable	Choose suitable rinsing fluid
Rinsing time is too low	Extend rinsing time
Rinsing interval is too long	Decrease rinsing interval

7.6 Sensor breaks often

Possible Cause	Remedy
Sensor is too long	choose suitable sensor (chapter 4.7)
Seals on the sensor are missing	Apply seals on the sensor (Chapter 4.7)
Process fluid contains sediments	Align protection cage (chapter 4.4)

7.7 Process Fluid escapes from the Control Window

Possible Cause	Remedy
Medium-touched seals are defective	Replace medium-touched seals (chapt. 6.6)

7.8 Compressed Air escapes from the Control Window

Possible Cause	Remedy
Drive unit is defective	Replace Drive Unit (chapter 6.10)

8 Technical Data

8.1 Norms

Pressure Equipment Directive (PED)

8.2 Material Properties

Medium Touched Components						
Holder						
SAW	High-grade-steel		Plastics			Seals
830	1.4404/316L					- EPDM FDA - FPM

Drive Unit			
SAW	Cylinder	Cylinder-Extension	Seals
All Types	1.4404/316	PA66 GF30	EPDM

8.3 Rinsing Connections

Thread	
Without nozzle	- G 1/8" (internal)
With nozzle	- G 1/4" (internal)

Rinsing pressure	
	1 - 4 bar

8.4 Sensors

Gel-Filled-Sensor			
SAW	l [mm]	d [mm]	PG
830	225	12	13,5

Liquid-Filled- Sensor with refill-nozzle			
SAW	l [mm]	d [mm]	PG
830	280	12	13,5

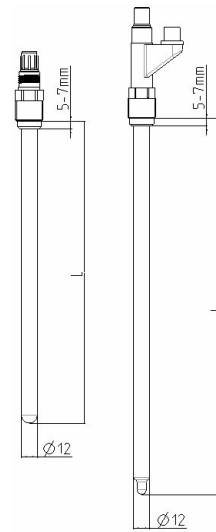

8.5 Pneumatic

Pneumatic Tubes		
	- outside	- internal
For control air	6 mm	4 mm
for position feedback	4 mm	2 mm

Compressed Air	
	<ul style="list-style-type: none"> - filtered 40nm, anhydrous - and oil-free - 4 - 6 bar - no continuous air consumption!

8.7 Ambient Conditions

Ambient temperature - 10 - 70 °C

Transport- and storage-temperature - 20 - 80 °C

8.8 Process Conditions SAW-830

permissible pressure max. PS: 16 bar
permissible temperature max TS: 140 °C

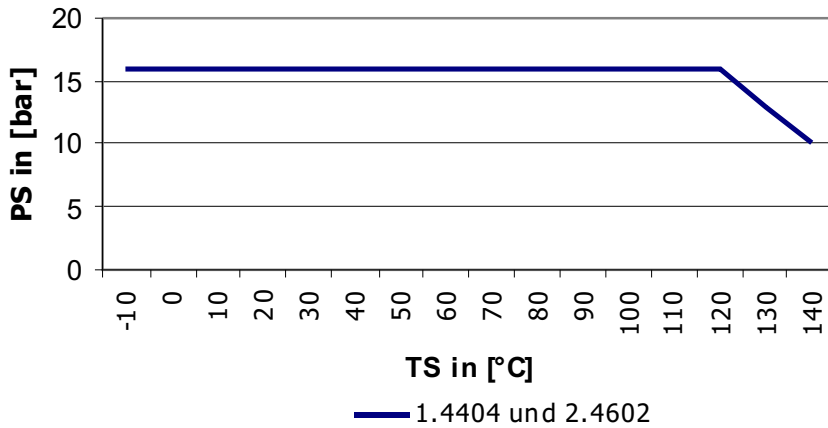

Fig. 20: Pressure-Temperature-Diagram SAW-830

seli GmbH Automatisierungstechnik

Zentrale

Dieselstraße 13

48485 Neuenkirchen

Tel. 05973 / 9474-0

Fax 05973 / 9474-74

E-Mail Zentrale@seli.de

Internet <http://www.seli.de>

