

Conductivity measuring unit for food and pharmaceutical industry

Instruction manual

SLI



modular @ analyse



Directory

Advanced features	1
Description	2
Safety instructions	3
Mechanical installation	4
Elektrical installation	5
Dimensional Drawings / Operator Control	6
Technical Data	7
Function principle.....	8
Configuring the SLI	9
Calibration	10

Instruction manual SLI

Conductivity measuring unit for food and pharmaceutical industry

Wetted parts in acid-proof, stainless steel or PEEK

Compact, food compatible, hygienic design

Process temperature -20...130°C

4 configurable measuring ranges

Adjustable, active temperature compensation

Insensitive to polarisation, adhesion and solids

LCD display for conductivity and temperature

4...20 mA output for conductivity and temperature

WARNING:

This product contains no replaceable parts.

In case of malfunction the product must be shipped to Bourdon-Haenni for repair.

Description

The SLI is a sensor for inductive measurement of conductivity. The compact design in all stainless steel enables installation in pipes from DN 40 and upwards.

Precise, configurable temperature compensation and remote setting of the four pre-configured measuring ranges make the SLI ideal for a wide range of conductivity measurements.

The integrated display for mS/cm and °C offers the user instant local supervision, which is an advantage e.g. in manually operated cleaning systems.

A high operating temperature limit is an advantage in SIP systems.

The optimised flow geometry and the fast response time makes the SLI particularly suitable in applications for separation of medias and measurements of cleaning agents in CIP equipment.

The accuracy is excellent even at very low conductivity and flow rates.

The comprehensive range of accessories make hygienic installation easy (Refer to separate data sheet).

Safety instructions

This instrument is built and tested according to EN 61326 and packed in technically safe condition. In order to maintain this condition and to ensure safe operation, the user must follow the hints and warnings given in this instruction.

WARNING

During the installation the valid national rules have to be observed. Ignoring the warnings may lead to severe personal injury or substantial damage to property.

The product must be operated by trained staff. Correct and safe operation of this equipment is dependent on proper transport, storage, installation and operation.

All electrical wiring must conform to local standards. In order to prevent stray electrical radiation, we recommend twisted and shielded input cables, as also to keep power supply cables separated from the input cables. The connection must be made according to the connecting diagrams.

WARNING

For electrical installation and commissioning of explosion protected devices, the data given in the conformity certificate as also the local regulations for installation of electrical apparatus within explosion protected areas must be considered. The intrinsically safe versions can be mounted in the explosion hazarded area according to ist specification only connected to a certified intrinsically safe supply loop with the corresponding electrical values.

Before switching on the power supply take care that other equipment is not affected. Ensure that the supply voltage and the conditions in the environment comply with the specification of the device.

Before switching off the supply voltage check the possible effects on other equipment and the processing system.

Mechanical Installation

Welding part

Please refer to “Accessories” data sheet. The welding part has an engraved mark. When the product has been mounted and correctly tightened the gland or M12 plug will align with this mark. Make sure that the gland/plug is pointing downwards to prevent fluids from penetrating into the instrument.

Cautions

Use only the authorised special designed accessories.

The product warranty is void when installed with other adapters.

Do not use teflon, paper or other gaskets.

Mount the hole at the sensor tip in the direction of the media flow.

It is not possible to turn the display relative to the channel bore.

After carefully insertion of the sensor into the welding part tighten the union with a torque of 20...30 Nm



After installation and configuration

Check the leak tightness of the sleeve.

Check the tightness of glands or M12 plugs.

Check the tightness of the cover.

Electrical installation

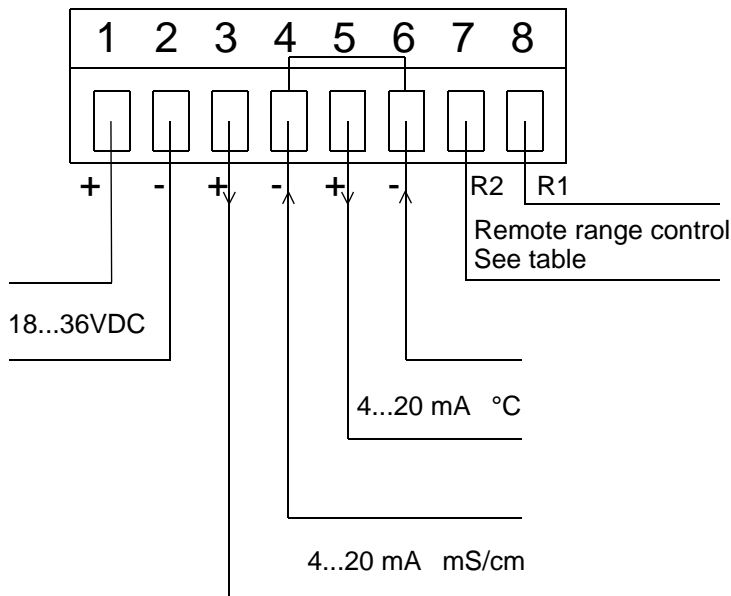

Range	R1	R2
	Volt	Volt
1	0/open	0/open
2	24	0
3	0	24
4	24	24

Jug shuttle range	Resolution for display
mS/cm	mS/cm
0...0,5	0.001
0...1	0.001
0...2	0.01
0...3	0.01
0...5	0.01
0...10	0.1
0...20	0.1
0...30	0.1
0...50	0.1
0...100	1.0
0...200	1.0
0...300	1.0
0...500	1.0
0...999	1.0

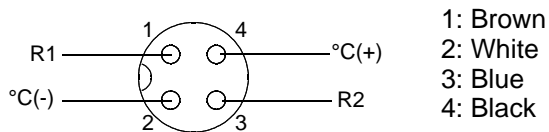
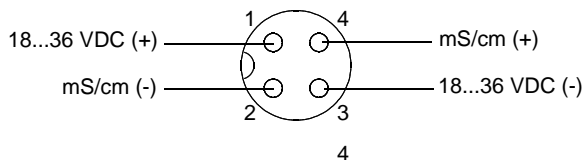

- 1: Brown
- 2: White
- 3: Blue
- 4: Black

Terminal 2 is connected to the housing via a protective diode.

Both 4...20 mA outputs are galvanically isolated from the power supply.
Terminal 4 and 6 are internally connected.
24V control signals (php) can be connected to terminals 7 and 8 for remote selection of one of four measuring ranges.

All four measuring ranges can individually be set to a range according to the table.

Dimensional Drawing

[mm]

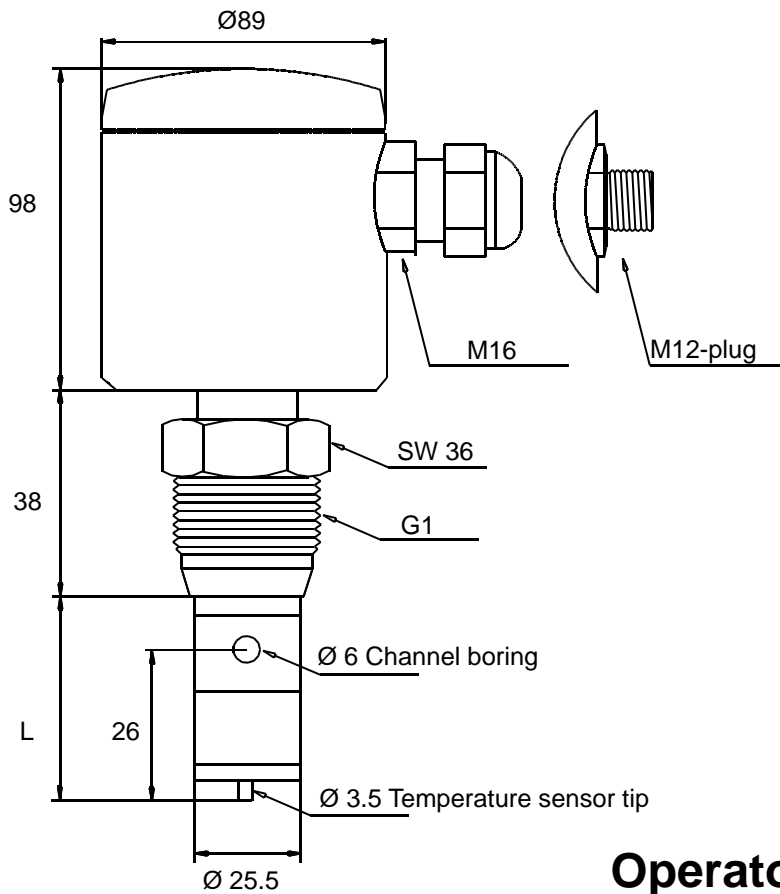

L = 37: Standard-sensor shaft
 L = 84: Extended sensor shaft

Operator Control

LC-Display

999,9 mS/cm
 139,9 °C

Max.-Indication

0,001 mS/cm
 000,1 °C

Min.-Indication

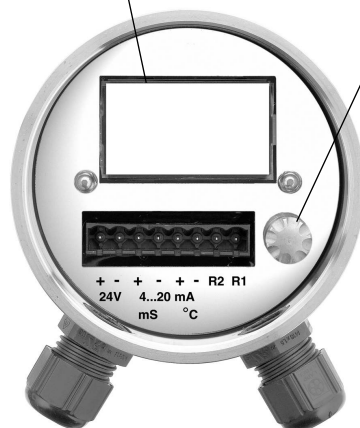

Jog shuttle
 PUSH: SW version
 TURN: Select menu
 PUSH: Config menu
 TURN: Select option
 Left: Decrease
 Right: Increase

The back-lit display indicates the conductivity in mS/cm and the temperature in °C. The jog shuttle is used for simple configuration of the measuring range(s) and the temperature coefficient(s) as well as the temperature range. Refer to the detailed description under "Configure the SLI"

Technical Data

Sensor

Inductive	2 toroidal-core transformers
Process connection	G1 hygienic
Insulating material	PEEK

Electrical connection

Cable gland M16	Plast
Plug M12	Nickel-plated brass

Mechanical data

Housing	Stainless Steel, W1.4301/AISI 304
Process connection	Stainless Steel, W1.4404/AISI 316L
Protection class	IP 67
Media pressure	Max. 10 bar
Adapters	Refer to "Accessories" data sheet

EMC data

Immunity	EN 61000-6-2
Emission	EN 50081-1

Operational conditions

Process temperature	-20...130°C (140°C <1hour)
Amb. Temperature	-20...60°C
Relative humidity	<100%, condensing

Electrical data

Power supply	18...36Vdc; max. 180 mA
Response time	$T_{90} < 3$ sec.
LCDisplay	All output data also valid for the display

Conductivity output

Measuring ranges	4 ranges, remote selectable
Ranges	0.5...999 mS/cm, configurable
Temp.compensation	0...5%K, configurable per range
Temperature drift	< 110 ppm/°C
Accuracy	± 1% of the selected range
Repeatability	0.2% f.s
Output	4...20 mA; max. 500 Ohm galv. Isolated from power supply
Overrange	21.6 mA

Temperature output

Accuracy	< ±0.2°C (20...50°C) < ±1.5°C (-20...140°C)
Resolution	0.1°C
Repeatability	0.2% f.s.
Temperature drift	< 150 ppm/°C
Output	4...20 mA; max. 500 Ohm galv. Isolated from power supply
Under/overrange	2.4/21.6 mA

Functional Principle

Inductive conductivity measurement is based on the principle of two series connected toroidal-core transformers (1) and (2). The primary side of the transformer 1 is controlled by an AC voltage generator.

The liquid flowing through the channel bore (3) in the measuring head form a conductor loop, which links between the secondary side of the transformer (1) and the primary side of the transformer (2). The output current is proportional with the conductivity of the media. Signal conditioning, amplification and conversion provides a 4...20 mA signal output from the galvanically isolated D/A converter.

The measured conductivity is highly dependable of the media temperature. Therefore the fast response temperature sensor in the tip (4) compensates for the temperature in the media.

The special processing unit offers maximum accuracy and reliability. The very low resolution of $1\mu\text{S}/\text{cm}$ together with a fast response time gives a high sensitivity. This ensures reliable detection of media even with minor differences in conductivity, such as different kinds of beer.

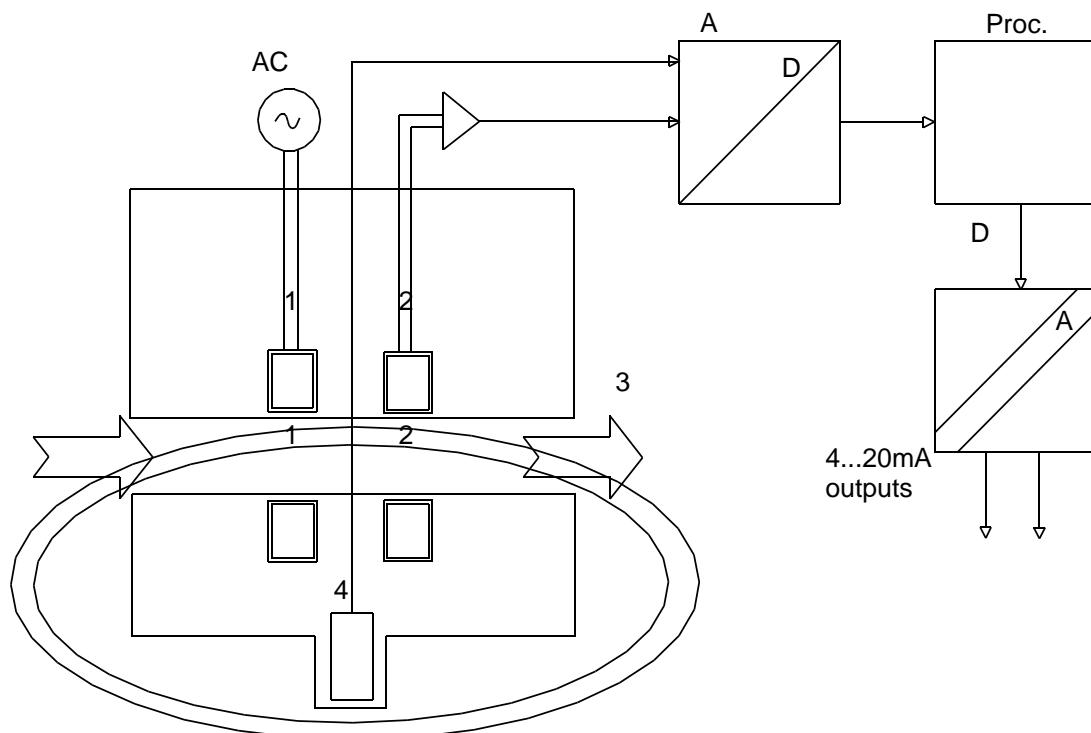

Configuring the SLI

Step	Subject	Range	Display	Jog-shuttle		Note
				Turn	Push	
1	Power on		starting ...			
2	Actual value	1	yyyyy mS zzzzz °C		Push	
3	SW version		Actual version		Push	
4	Actual value	1	yyyyy mS zzzzz °C	Right		
5	Set Range 1	1	4 ... 20 mA Actual range, mS		Push	Note 1
6		1 ▲▼	4 ... 20 mA Set range, mS	Left/Right	Push to set	Left: Decrease Right: Increase
7		1	4 ... 20 mA New range, mS	Right		
8		1 1	Resolution Actual Coefficient		Push	Note 2
9		1 ▲▼	Resolution Set Coefficient	Left/Right	Push to set	
10		1 1	Resolution New Coefficient	Right		
11	Set Range 2	2	4 ... 20 mA Actual range, mS		Push	
Repeat steps 5...10 for ranges 2...4.						
12	Set temperature range		4 ... 20 mA °C Actual range		Push	
13	Set temperature range		4 ... 20 mA °C Select range	Left/Right	Push to set	Note 3

Calibration of the SLI

This procedure describes an easy procedure for determination of the temperature coefficient (TC) of a media.

1. Dip the measuring head in a sample media making sure that the channel bore is completely covered with media without bubbles.
2. Heat the media to 25.0 °C
3. Ensure adequate circulation in the media.
4. Note the indicated conductivity.
5. Heat the media to min. 60°C
6. Set the TC in the setup menu to indicate exactly the same conductivity as it is at 25°C

Warnings:

1. A higher TC value will result in a lower conductivity induction.
2. Do not use the TC value to adjust a measured value. The instrument has been calibrated from the factory.
3. Inadequate circulation in the media will cause a slight heating of the channel bore resulting in a false measurement.

Note1:

After 60 seconds without any action from the user the instrument switches back to normal mode indicating the actual measured values.

Note 2:

Each of the four measuring ranges is assigned its own setting for temperature compensation.

The compensation is adjustable in the range 0.00...4.98 % K.

The compensation is defined as being linear at 25°.

Note 3:

Selectable temperature ranges:

0...150, -20...130, 0...100, -20...80, 0...50, -10...40, -20...150°C

Design and specifications subject to change
without notice

Oktober 2005

seli GmbH Automatisierungstechnik

central office

Dieselstraße 13

48485 Neuenkirchen

Tel. 05973 / 9474-0

Fax 05973 / 9474-74

E-Mail Zentrale@seli.de

Internet <http://www.seli.de>



Automatisierungstechnik